



This is a digital copy of a book that was preserved for generations on library shelves before it was carefully scanned by Google as part of a project to make the world's books discoverable online.

It has survived long enough for the copyright to expire and the book to enter the public domain. A public domain book is one that was never subject to copyright or whose legal copyright term has expired. Whether a book is in the public domain may vary country to country. Public domain books are our gateways to the past, representing a wealth of history, culture and knowledge that's often difficult to discover.

Marks, notations and other marginalia present in the original volume will appear in this file - a reminder of this book's long journey from the publisher to a library and finally to you.

Usage guidelines

Google is proud to partner with libraries to digitize public domain materials and make them widely accessible. Public domain books belong to the public and we are merely their custodians. Nevertheless, this work is expensive, so in order to keep providing this resource, we have taken steps to prevent abuse by commercial parties, including placing technical restrictions on automated querying.

We also ask that you:

- + *Make non-commercial use of the files* We designed Google Book Search for use by individuals, and we request that you use these files for personal, non-commercial purposes.
- + *Refrain from automated querying* Do not send automated queries of any sort to Google's system: If you are conducting research on machine translation, optical character recognition or other areas where access to a large amount of text is helpful, please contact us. We encourage the use of public domain materials for these purposes and may be able to help.
- + *Maintain attribution* The Google "watermark" you see on each file is essential for informing people about this project and helping them find additional materials through Google Book Search. Please do not remove it.
- + *Keep it legal* Whatever your use, remember that you are responsible for ensuring that what you are doing is legal. Do not assume that just because we believe a book is in the public domain for users in the United States, that the work is also in the public domain for users in other countries. Whether a book is still in copyright varies from country to country, and we can't offer guidance on whether any specific use of any specific book is allowed. Please do not assume that a book's appearance in Google Book Search means it can be used in any manner anywhere in the world. Copyright infringement liability can be quite severe.

About Google Book Search

Google's mission is to organize the world's information and to make it universally accessible and useful. Google Book Search helps readers discover the world's books while helping authors and publishers reach new audiences. You can search through the full text of this book on the web at <http://books.google.com/>

UC-NRLF

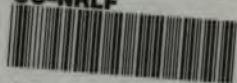

EB 33 347



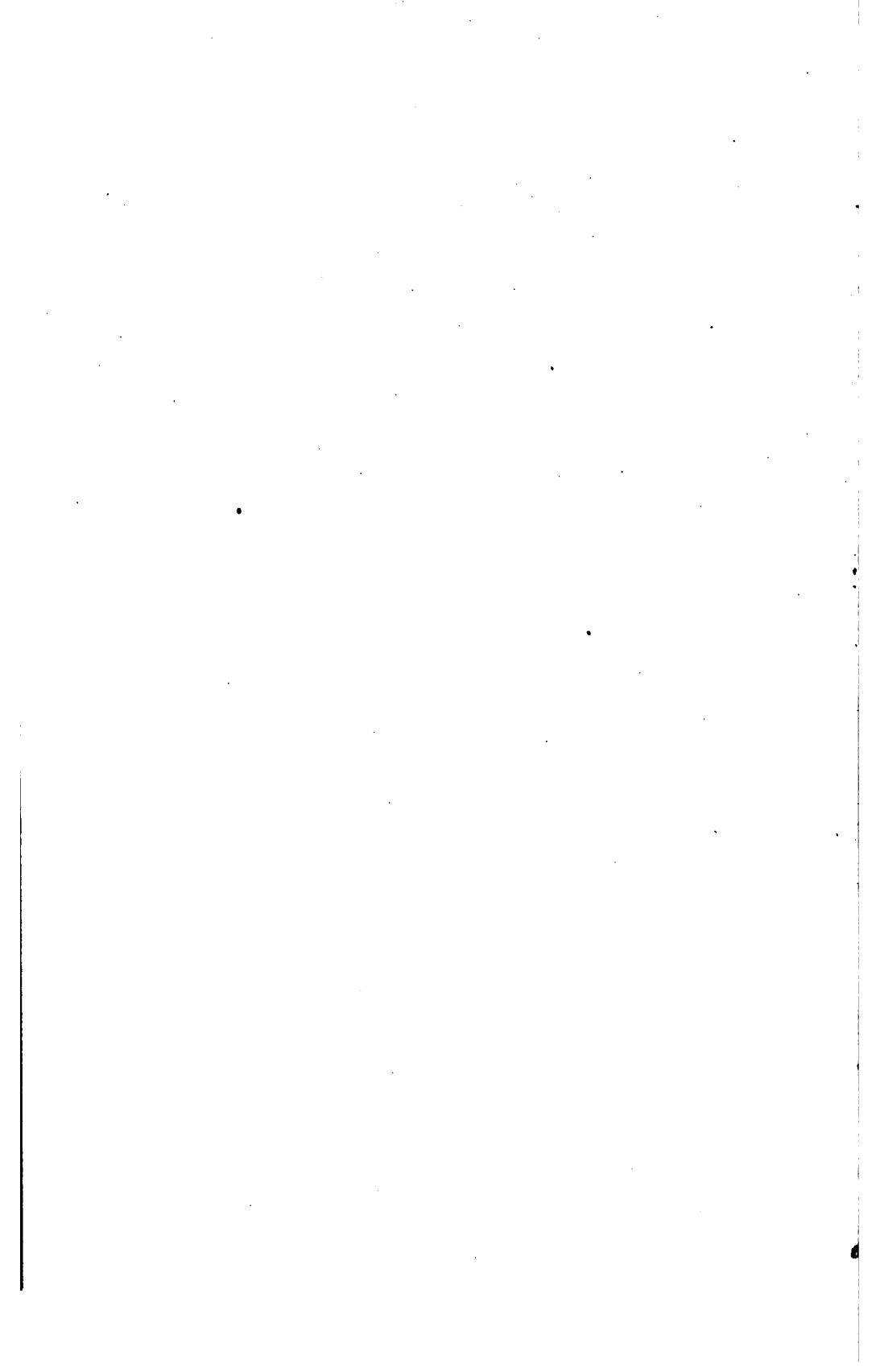

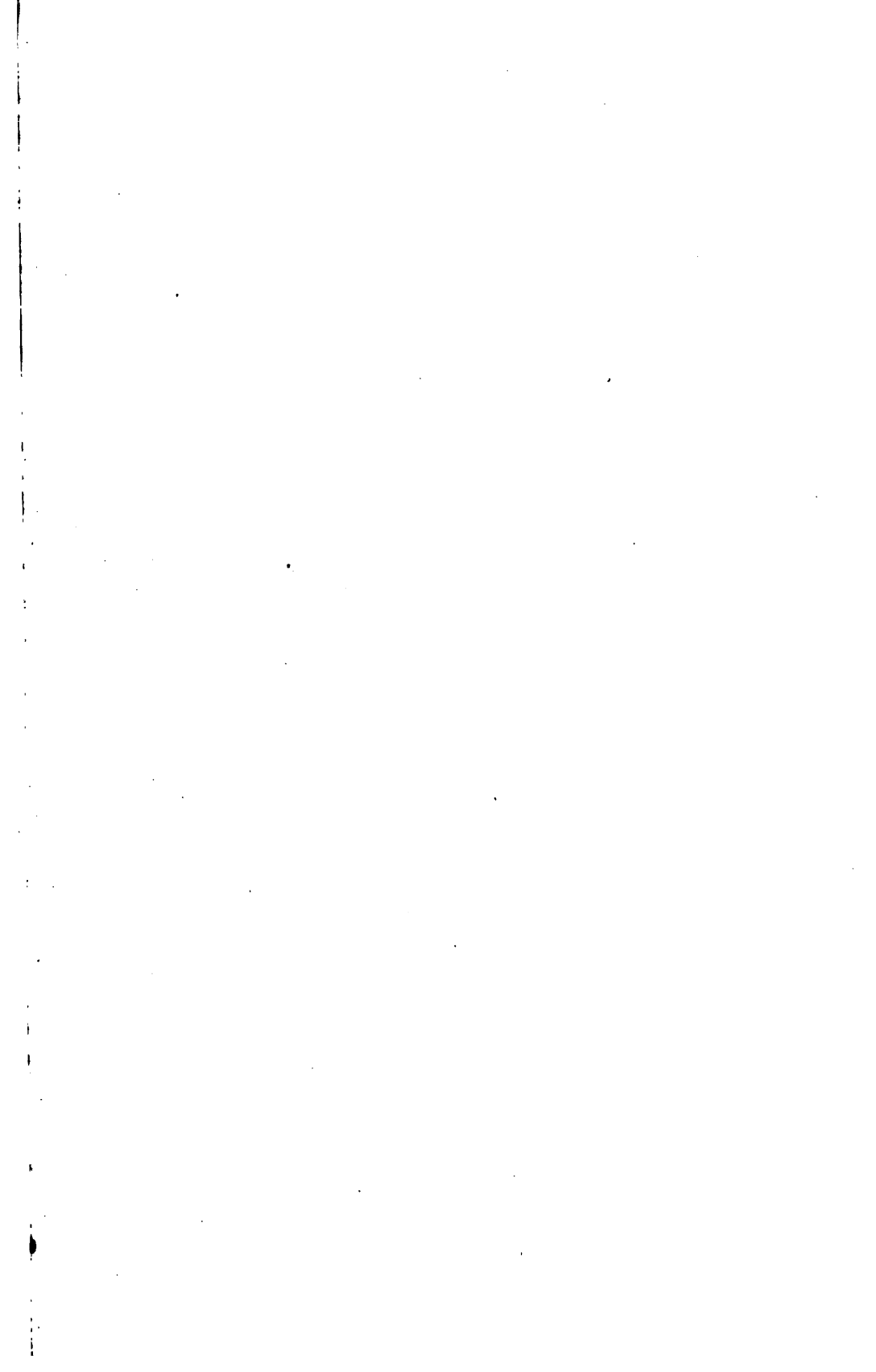

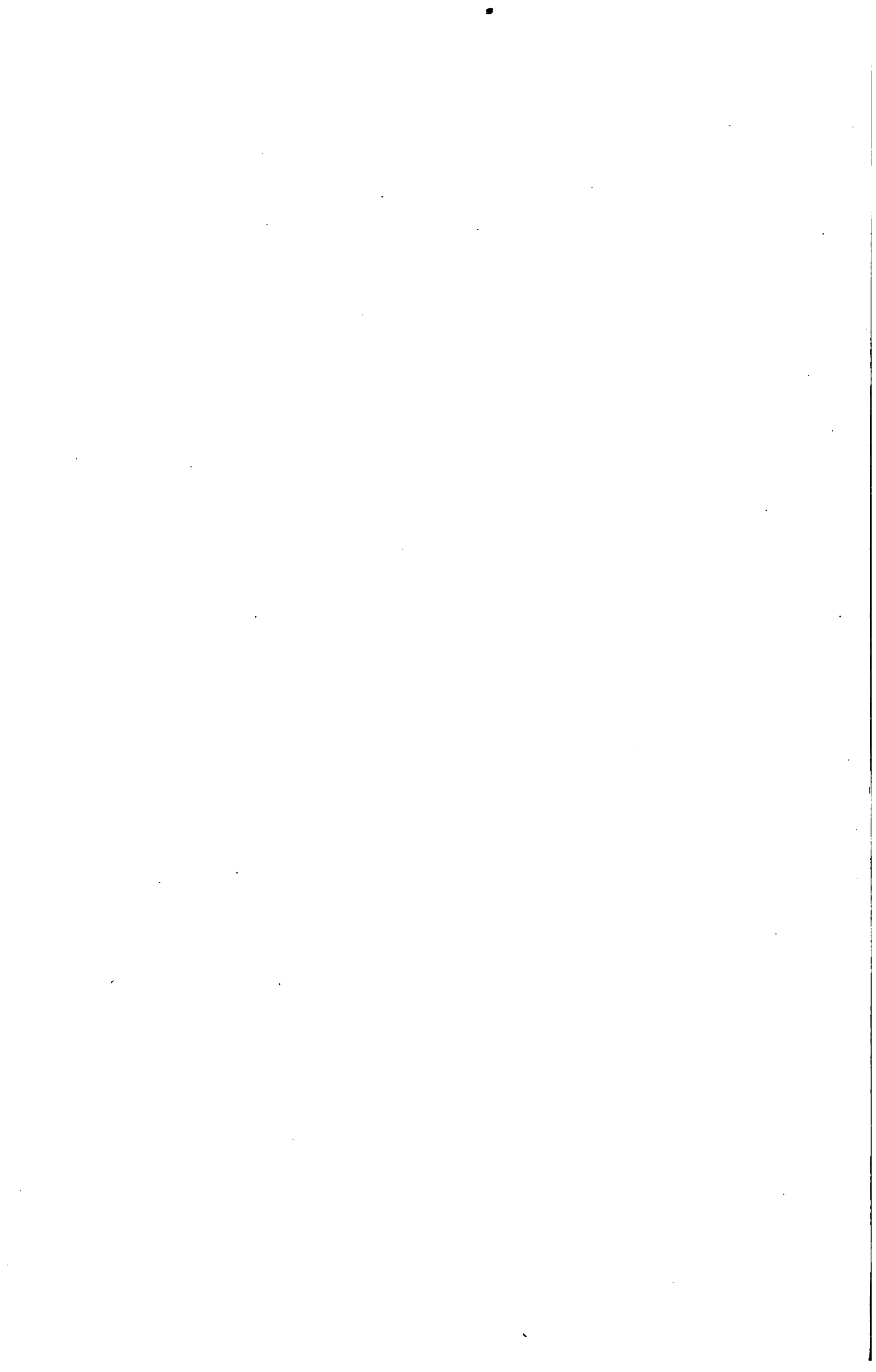

A COURSE IN
MECHANICAL DRAWING.

BY

JOHN S. REID,

*Instructor in Mechanical Drawing and Designing,
Sibley College, Cornell University,
Ithaca, N. Y.*

FIRST EDITION.

FIRST THOUSAND.



NEW YORK.

JOHN WILEY & SONS.

LONDON: CHAPMAN & HALL, LIMITED.

1898.

T 353
R4

Copyright, 1898,
BY
JOHN S. REID.

75022



PREFACE.

IN the course of a large experience as an instructor in drawing and designing, the author of this work has often been called upon to teach the elements of mechanical drawing to students in marine, electrical, railway, and mechanical engineering. Having tried and failed to find a book on the subject that was entirely suitable for his use as a text-book, he has found it necessary to prepare the present work.

This course contains, in the author's judgment, a complete and concise statement, accompanied by examples, of the essential principles of mechanical drawing—all that any young man of ordinary intelligence needs to master, by careful study, the more advanced problems met with in machine construction and design. Such works as the author has tried, although most excellent from certain standpoints, were either incomplete in some of the divisions of the subject or too voluminous and elementary in the treatment of details.

The author does not imagine this work is perfect, but he believes that it comes nearer what is needed in teaching the elements of mechanical drawing in technical schools, high schools, evening drawing schools, and colleges than any work he has examined.

The chapter on Conventions will be appreciated by students

PREFACE.

when called upon to execute working drawings in practical work. The methods described are considered by the author to be those which have met with general approval by the experienced American draftsmen of the present time.

My acknowledgments are due to E. C. Cleaves, professor of drawing, Sibley College, Cornell University, for reading the manuscript and making some valuable suggestions.

THE AUTHOR.

April 1, 1898.

CONTENTS.

INTRODUCTION.

	PAGE
THE COMPLETE OUTFIT, ILLUSTRATED.....	I

CHAPTER I.

INSTRUMENTS.....	7
Use of Instruments.....	7
Pencil.....	7
Drawing Pen.....	9
Triangles.....	11
T Square.....	11
Drawing Board.....	11
Sibley College Scale.....	12
Scale Guard.....	12
Compasses.....	13
Dividers or Spacers.....	13
Spring Bows.....	14
Irregular Curves.....	14
Protractor.....	14

CHAPTER II.

GEOMETRICAL DRAWING.....	16
--------------------------	----

CHAPTER III.

CONVENTIONS.....	56
------------------	----

CHAPTER IV.

LETTERING AND FIGURING.....	64
-----------------------------	----

CHAPTER V.

ORTHOGRAPHIC PROJECTION.....	74
Shade Lines and Shading.....	103
Conventions.....	104
Shading.....	106
Isometrical Drawings.....	112
Working Drawings.....	118





MECHANICAL DRAWING.

INTRODUCTION.

A NEED has been felt by instructors and students, especially in technical courses, for a text-book that would illustrate the fundamental principles of mechanical drawing in such a practical, lucid, direct and progressive way as to enable the instructor to teach, and the student to acquire, the greatest number of the essential principles involved, and the ability to apply them, in a draftsman-like manner, in the shortest space of time.

With this in mind, the present work has been prepared from the experience of the writer, a practical draftsman and teacher for over fifteen years.

THE COMPLETE OUTFIT.

The complete outfit for students in mechanical drawing in Sibley College is as follows:

(1) THE DRAWING-BOARD for freshman work is $17'' \times 22'' \times \frac{3}{8}''$, the same as that used for free-hand drawing. The board for sophomore and junior drawing is $20'' \times 26'' \times$ not more than $1''$ in thickness. The material should be soft pine and constructed as shown by Fig. 1.

- (2) PAPER, quality and size to suit.
- (3) PENCILS, one 6H and one 4H Koh-i-noor or Faber, also one Eagle Pilot No. 2 with rubber tip.
- (4) The T-SQUARE for freshman work is furnished by the

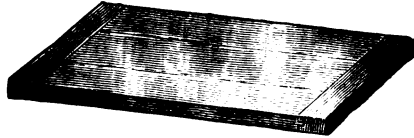

FIG. 1.

department; a plain pearwood T-square with a fixed head is all that is necessary for sophomore or junior work. Length to suit drawing-board.

(5) INSTRUMENTS. "The Sibley College Set," shown by Fig. 2, was compiled by the writer, and is recommended as a first-class medium-priced set of instruments. It contains



FIG. 2.

A COMPASS, $5\frac{1}{2}$ " long, with fixed needle-point, pencil, pen and lengthening bar.

A SPRING BOW PENCIL, 3" long.

A " " PEN, 3" long.

A " " SPACER, 3" long.

A DRAWING-PEN, medium length.

A HAIR-SPRING DIVIDER, 5" long.

A nickel-plated box with leads.



(6) A TRIANGULAR BOXWOOD SCALE graduated as

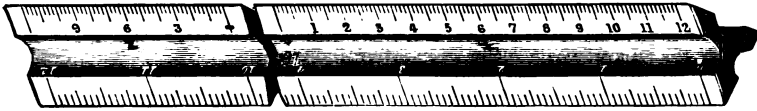

FIG. 3.

follows: 4" and 2", 3" and 1½", 1" and ½", ¾" and ⅜", ⅙" and ⅓".

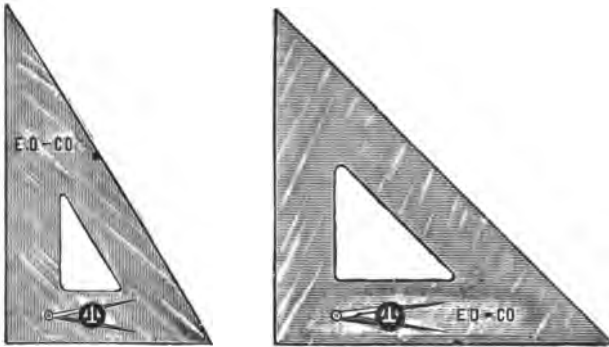

FIG. 4.

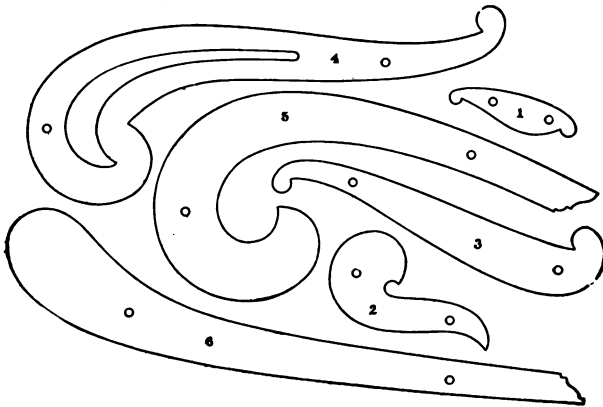

FIG. 5

- (7) 1 TRIANGLE $30^{\circ} \times 60^{\circ}$, celluloid, 10" long. Fig. 4.
 I " 45° , " 7" " "
 (8) "SIBLEY COLLEGE SET" of IRREGULAR CURVES.
 (9) GLASS-PAPER PENCIL SHARPENER.



FIG. 6.

- (10) INK, black waterproof, S.&H. Fig. 7.
 (11) " red " Higgins. Fig. 8.
 (12) " blue " "



FIG. 7.



FIG. 8.

- (13) INK ERASER, Faber's Typewriter.
 (14) PENCIL ERASER, Tower's Multiplex Rubber. Fig. 9.

(15) SPONGE RUBBER or FABER'S KNEADED RUBBER.
Fig. 10.



FIG. 9.

(16) TACKS, a small box of 1 oz. tacks.

(17) WATER-COLORS, $\frac{1}{2}$ pan each of Payne's Gray, Crimson Lake, Prussian Blue, Burnt Sienna, and Gamboge. Windsor & Newton. Fig. 11.

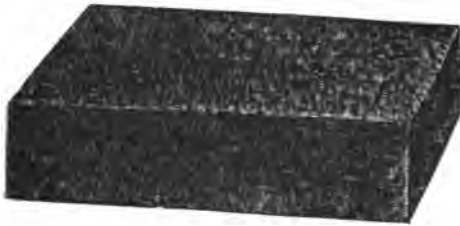

FIG. 10.



FIG. 11.

(18) TINTING BRUSH, Camel's Hair No. 10. Fig. 12.

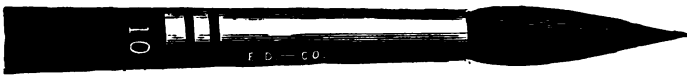

FIG. 12.

(19) TINTING SAUCER. Fig. 13.

(20) WATER GLASS. Fig. 14.

(21) ARKANSAS OIL-STONE. $2'' \times \frac{1}{2}'' \times \frac{1}{8}''$.

(22) PIECE OF SHEET CELLULOID No. 3000, dull on both sides.

(23) PROTRACTOR, German silver, about 5" diam. Fig. 15.

(24) SCALE GUARD, " " Fig. 16.



FIG. 13.



FIG. 14.

(25) SHEET OF TRACING-CLOTH, 18" × 24".

(26) WRITING-PEN, point, "Gillott" No. 303.

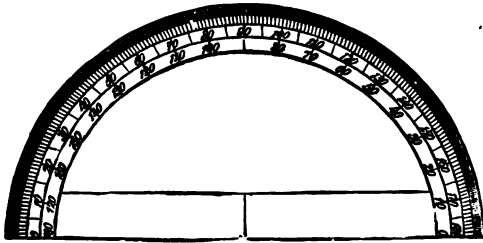

FIG. 15.



FIG. 16.

(27) Piece of SHEET BRASS, 4" × 4".

(28) NEEDLES, two with handles.

The following numbers of "The Complete Outfit" are all that the student will be required to purchase for freshman mechanical drawing (No. 2 Register, '97-'98): 2, 3, 5, 6, 7, 8, 9, 10, 13, 14, 16, 26.

The remainder of the outfit may be purchased during the sophomore and junior years.

CHAPTER I.

INSTRUMENTS.

IT is a common belief among students that any kind of cheap instrument will do with which to learn mechanical drawing, and not until they have acquired the proper use of the instruments should they spend money in buying a first-class set. This is one of the greatest mistakes that can be made. Many a student has been discouraged and disgusted because, try as he would, he could not make a good drawing, using a set of instruments with which it would be difficult for even an experienced draftsman to make a creditable showing.

If it is necessary to economize in this direction it is better and easier to get along with a fewer number, and have them of the best, than it is to have an elaborate outfit of questionable quality.

The instruments composing the "Sibley College Set" are made by T. Alteneder & Sons, and are certainly as good as the best. See Fig. 17.

USE OF INSTRUMENTS.

The Pencil.—Designs of all kinds are usually worked out in pencil first, and if to be finished and kept they are inked in and sometimes colored and shaded; but if the drawing is only to be finished in pencil, then all the lines except construction, center, and dimension lines should be made broad and dark,

so that the drawing will stand out clear and distinct. It will be noticed that this calls for two kinds of pencil-lines, the first a thin, even line made with a hard, fine-grained lead-pencil, not less than 6H (either Koh-i-noor or Faber's), and sharpened to a knife-edge in the following manner: The lead should be carefully bared of the wood with a knife for about $\frac{1}{8}$ "', and the wood neatly tapered back from that point; then lay the lead upon the glass-paper sharpener illustrated in the outfit, and carefully rub to and fro until the pencil assumes a long taper from the wood to the point; now turn it over and do the same with the other side, using toward the last a slightly oscillating motion on both sides until the point has assumed a sharp, thin, knife-edge endwise and an elliptical contour the other way.

This point should then be polished on a piece of scrap drawing-paper until the rough burr left by the glass-paper is removed, leaving a smooth, keen, ideal pencil-point for drawing straight lines.

With such a point but little pressure is required in the hands of the draftsman to draw the most desirable line, one that can be easily erased when necessary and inked in to much better advantage than if the line had been made with a blunt point, because, when the pencil-point is blunt the inclination is to press hard upon it when drawing a line. This forms a groove in the paper which makes it very difficult to draw an even inked line.

The second kind of a pencil-line is the broad line, as explained above; it should be drawn with a somewhat softer pencil, say 4H, and a thicker point.

All lines not necessary to explain the drawing should be

erased before inking or broadening the pencil-lines, so as to make a minimum of erasing and cleaning after the drawing is finished.

When drawing pencil-lines, the pencil should be held in a plane passing through the edge of the T-square perpendicular to the plane of the paper and making an angle with the plane of the paper equal to about 60° .

Lines should always be drawn from left to right. A soft conical-pointed pencil should be used for lettering, figuring, and all free-hand work.

The Drawing-pen.—The best form, in the writer's opinion, is that shown in Fig. 17. The spring on the upper blade

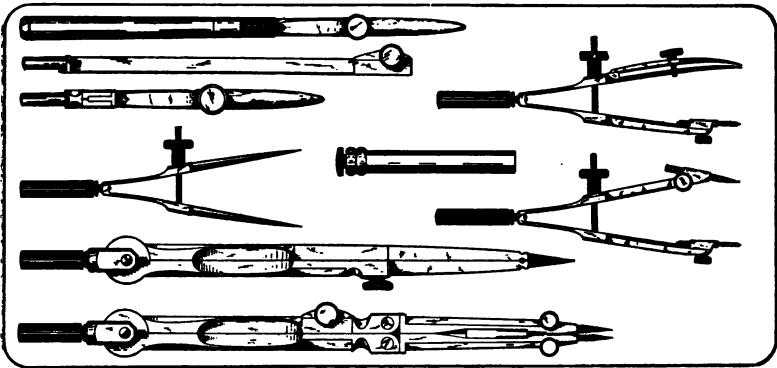

FIG. 17.

spreads the blades sufficiently apart to allow for thorough cleaning and sharpening. The hinged blade is therefore unnecessary. The pen should be held in a plane passing through the edge of the T-square at right angles to the plane of the paper, and making an angle with the plane of the paper ranging from 60° to 90° .

The best of drawing-pens will in time wear dull on the point, and until the student has learned from a competent

teacher how to sharpen his pens it would be better to have them sharpened by the manufacturer.

It is difficult to explain the method of sharpening a drawing-pen.

If one blade has worn shorter than the other, the blades should be brought together by means of the thumb-screw, and placing the pen in an upright position draw the point to and fro on the oil-stone in a plane perpendicular to it, raising and lowering the handle of the pen at the same time, to give the proper curve to the point. The Arkansas oil-stones (No. 21 of "The Complete Outfit") are best for this purpose.

The blades should next be opened slightly, and holding the pen in the right hand in a nearly horizontal position, place the lower blade on the stone and move it quickly to and fro, slightly turning the pen with the fingers and elevating the handle a little at the end of each stroke. Having ground the lower blade a little, turn the pen completely over and grind the upper blade in a similar manner for about the same length of time; then clean the blades and examine the extreme points, and if there are still bright spots to be seen continue the grinding until they entirely disappear, and finish the sharpening by polishing on a piece of smooth leather.

The blades should not be too sharp, or they will cut the paper. The grinding should be continued only as long as the bright spots show on the points of the blades.

When inking, the pen should be held in about the same position as described for holding the pencil. Many draftsmen hold the pen vertically. The position may be varied with good results as the pen wears. Lines made with the pen should only be drawn from left to right.

THE TRIANGLES.

The triangles shown at Fig. 4 (in "The Complete Outfit") are 10" and 7" long respectively, and are made of transparent celluloid. The black rubber triangles sometimes used are but very little cheaper (about 10 cents) and soon become dirty when in use; the rubber is brittle and more easily broken than the celluloid.

Angles of 15° , 75° , 30° , 45° , 60° , and 90° can readily be drawn with the triangles and T-square. Lines parallel to oblique lines on the drawing can be drawn with the triangles by placing the edge representing the height of one of them so as to coincide with the given line, then place the edge representing the hypotenuse of the other against the corresponding edge of the first, and by sliding the upper on the lower when holding the lower firmly with the left hand any number of lines may be drawn parallel to the given line.

The methods of drawing perpendicular lines and making angles with other lines within the scope of the triangles and T-square are so evident that further explanation is unnecessary.

THE T-SQUARE.

The use of the T-square is very simple, and is accomplished by holding the head firmly with the left hand against the left-hand end of the drawing-board, leaving the right hand free to use the pen or pencil in drawing the required lines.

THE DRAWING-BOARD.

If the left-hand edge of the drawing-board is straight and even and the paper is tacked down square with that edge and

the T-square, then horizontal lines parallel to the upper edge of the paper and perpendicular to the left-hand edge may be drawn with the T-square, and lines perpendicular to these can be made by means of the triangles, or *set squares*, as they are sometimes called.

THE SIBLEY COLLEGE SCALE.

This scale, illustrated in Fig. 3 (in "The Complete Outfit"), was arranged to suit the needs of the students in Sibley College. It is triangular and made of boxwood. The six edges are graduated as follows; $\frac{1}{8}''$ or full size, $\frac{1}{8}''$, $\frac{3}{4}''$ and $\frac{3}{8}'' = 1$ ft., $1''$ and $\frac{1}{2}'' = 1$ ft., $3''$ and $1\frac{1}{2}'' = 1$ ft., and $4''$ and $2'' = 1$ ft.

Drawings of very small objects are generally shown enlarged—e.g., if it is determined to make a drawing twice the full size of an object, then where the object measures one inch the drawing would be made $2''$, etc.

Larger objects or small machine parts are often drawn full size—i.e., the same size as the object really is—and the drawing is said to be made to the scale of full size.

Large machines and large details are usually made to a reduced scale—e.g., if a drawing is to be made to the scale of $2'' = 1$ ft., then $2''$ measured by the standard rule would be divided into 12 equal parts and each part would represent $1''$. See Fig. 81*b*.

THE SCALE GUARD.

This instrument is shown in Fig. 16 (in "The Complete Outfit"). It is employed to prevent the scale from turning, so that the draftsman can use it without having to look for

the particular edge he needs every time he wants to lay off a measurement.

THE COMPASSES.

When about to draw a circle or an arc of a circle, take hold of the compass at the joint with the thumb and two first fingers, guide the needle-point into the center and set the pencil or pen leg to the required radius, then move the thumb and forefinger up to the small handle provided at the top of the instrument, and beginning at the lowest point draw the line clockwise. The weight of the compass will be the only down pressure required.

The sharpening of the lead for the compasses is a very important matter, ~~and cannot be emphasized too much~~. Before commencing a drawing it pays well to take time to properly sharpen the pencil and the lead for compasses and to keep them always in good condition.

The directions for sharpening the compass leads are the same as has already been given for the sharpening of the straight-line pencil.

THE DIVIDERS OR SPACERS.

This instrument should be held in the same manner as described for the compass. It is very useful in laying off equal distances on straight lines or circles. To divide a given line into any number of equal parts with the dividers, say 12, it is best to divide the line into three or four parts first, say 4, and then when one of these parts has been subdivided accurately into three equal parts, it will be a simple matter to step off these latter divisions on the remaining three-fourths

of the given line. Care should be taken not to make holes in the paper with the spacers, as it is difficult to ink over them without blotting.

THE SPRING BOWS.

These instruments are valuable for drawing the small circles and arcs of circles. It is very important that all the small arcs, such as fillets, round corners, etc., should be carefully pencilled in before beginning to ink a drawing. Many good drawings are spoiled because of the bad joints between small arcs and straight lines.

When commencing to ink a drawing, all small arcs and small circles should be inked first, then the larger arcs and circles, and the straight lines last. This is best, because it is much easier to know where to stop the arc line, and to draw the straight line tangent to it, than *vice versa*.

IRREGULAR CURVES.

The Sibley College Set of Irregular Curves shown in Fig. 5 are useful for drawing irregular curves through points that have already been found by construction, such as ellipses, cycloids, epicycloids, etc., as in the cases of gear-teeth, cam outlines, rotary pump wheels, etc.

When using these curves, that curve should be selected that will coincide with the greatest number of points on the line required.

THE PROTRACTOR.

This instrument is for measuring and constructing angles. It is shown in Fig. 15. It is used as follows when measuring

an angle: Place the lower straight edge on the straight line which forms one of the sides of the angle, with the nick exactly on the point of the angle to be measured. Then the number of degrees contained in the angle may be read from the left, clockwise.

In constructing an angle, place the nick at the point from which it is desired to draw the angle, and on the outer circumference of the protractor, find the figure corresponding to the number of degrees in the required angle, and mark a point on the paper as close as possible to the figure on the protractor; after removing the protractor, draw a line through this point to the nick, which will give the required angle.

CHAPTER II.

GEOMETRICAL DRAWING.

The following problems are given to serve a double purpose: to teach the use of drawing instruments, and to point out those problems in practical geometry that are most useful in mechanical drawing, and to impress them upon the mind of the student so that he may readily apply them in practice.

The drawing-paper for this work should be divided temporarily, with light pencil-lines, into as many squares and rectangles as may be directed by the instructor, and the drawings made as large as the size of the squares will permit. The average size of the squares should be not less than 4". When a sheet of drawings is finished these boundary lines may be erased.

It will be noticed in the illustrations of this chapter that all construction lines are made very narrow, and given and required lines quite broad. This is sufficient to distinguish them, and employs less time than would be necessary if the construction lines were made broken, as is often the case.

If time will permit, it is advisable to ink in some of these drawings toward the last. In that event, the given lines may be red, the construction lines blue, and the required lines black.

But even when inked in in black, the broad and narrow

lines would serve the purpose very well without the use of colored inks.

The principal thing to be aimed at in making these drawings is accuracy of construction. All dimensions should be laid off carefully, correctly, and quickly. Straight lines joining arcs should be exactly tangent, so that the joints cannot be noticed. It is the little things like these that make or mar a drawing, and if attended to or neglected they will make or mar the draftsman. The constant endeavor of the student should be to make every drawing he begins more accurate, quicker and better in every way than the preceding one.

A drawing should never be handed in as finished until the student is perfectly sure that he cannot improve it in any way whatever, for the act of handing in a drawing is the same, or should be the same, as saying This is the best that I can do; I cannot improve it; it is a true measure of my ability to make this drawing.

If these suggestions are faithfully followed throughout this course, success awaits *any one* who earnestly desires it.

FIG. 18. TO BISECT A FINITE STRAIGHT LINE.—With A and B in turn as centers, and a radius greater than the half of AB , draw arcs intersecting at E and F . Join EF bisecting AB at C .

An arc of a circle may be bisected in the same way.

FIG. 19. TO ERECT A PERPENDICULAR AT THE END OF THE LINE.—Assume the point E above the line as center and radius EB describe an arc CBD cutting the line AB in the point C . From C draw a line through E cutting the arc in D . Draw DB the perpendicular.

FIG. 20. THE SAME PROBLEM: A SECOND METHOD.—

With center B and any radius as BC describe an arc CDE with the same radius; measure off the arcs CD and DE . With C and D as centers and any convenient radius describe arcs intersecting at F . FB is the required perpendicular.

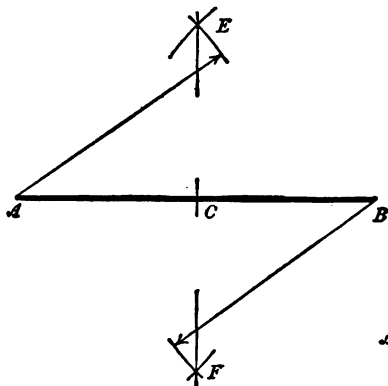

FIG. 18.

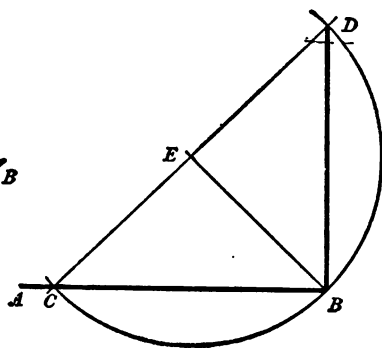

FIG. 19.

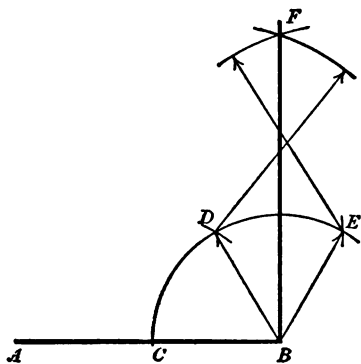

FIG. 20.

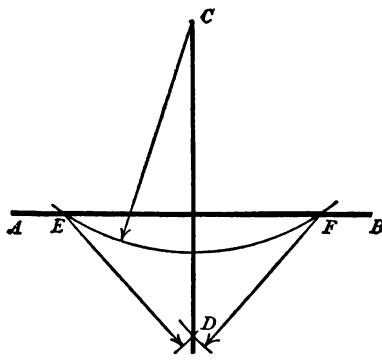

FIG. 21.

FIG. 21. TO DRAW A PERPENDICULAR TO A LINE FROM A POINT ABOVE OR BELOW IT.—Assume the point C above the line. With center C and any suitable radius cut the line AB in E and F . From E and F describe arcs cutting in D . Draw CD the perpendicular required.

FIG. 22. TO BISECT A GIVEN ANGLE.—With A as center and any convenient radius describe the arc BC . With B and C as centers and any convenient radius draw arcs intersecting at D . Join AD , then angle $BAD = \text{angle } DAC$.

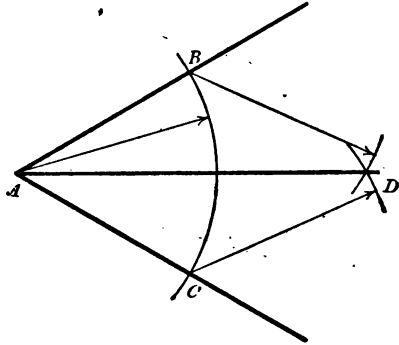

FIG. 22.

FIG. 23. TO DRAW A LINE PARALLEL TO A GIVEN LINE AB THROUGH A GIVEN POINT C .—From any point on AB as B with radius BC describe an arc cutting AB in A . From A with the same radius describe arc BD . From B with AC as radius cut arc BD in D . Draw CD . Line CD is parallel to AB .

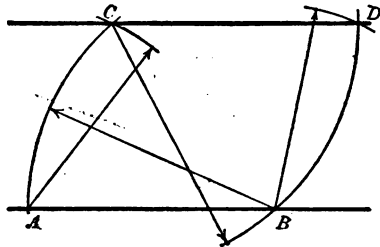

FIG. 23.

FIG. 24. FROM A POINT D ON THE LINE DE TO SET OFF AN ANGLE EQUAL TO THE GIVEN ANGLE BAC .—From

A with any convenient radius describe arc BC . From D with the same radius describe arc EF . With center E and radius BC cut arc EF in F . Join DF . Angle EDF is = angle BAC .

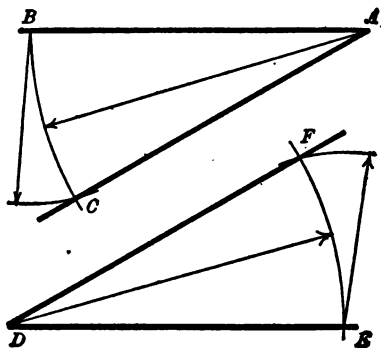

FIG. 24.

FIG. 25. TO DIVIDE AN ANGLE INTO TWO EQUAL PARTS, WHEN THE LINES DO NOT EXTEND TO A MEETING POINT.—Draw the line CD and CE parallel and at equal dis-

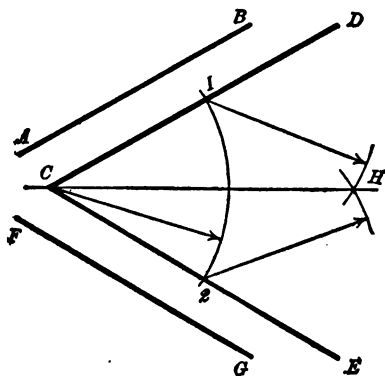

FIG. 25.

tances from the lines AB and FG . With C as center and any radius draw arcs 1, 2. With 1 and 2 as centers and any con-

venient radius describe arcs intersecting at H . A line through C and H divides the angle into two equal parts.

FIG. 26. TO CONSTRUCT A RHOMBOID HAVING ADJACENT SIDES EQUAL TO TWO GIVEN LINES AB AND AC , AND AN ANGLE EQUAL TO A GIVEN ANGLE A .—Draw line DE equal to AB . Make $D = \text{angle } A$. Make $DF = AC$. From F with line AB as radius and from E with line AC as radius describe arcs cutting in G . Join FG and EG .

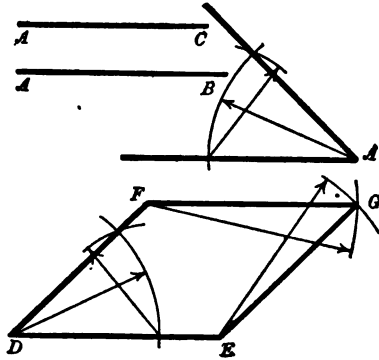
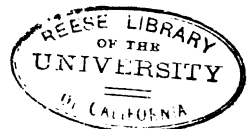

FIG. 26.

FIG. 27. TO DIVIDE THE LINE AB INTO ANY NUMBER OF EQUAL PARTS, SAY 15.—Draw a line CD parallel to AB , of any convenient length. From C set off along this line the number of equal parts into which the line AB is to be divided. Draw CA and DB and produce them until they intersect at E . Through each one of the points 1, 2, 3, 4, etc., draw lines to the point E , dividing the line AB into the required number of equal parts.

This problem is useful in dividing a line when the point required is difficult to find accurately—e.g., in Fig. 28 AB is the *pitch* of the spur gear, partly shown, which includes a



space and a tooth and is measured on the *pitch circle*. In cast gears the space is made larger than the thickness of the tooth, the proportion being about 6 to 5—i.e., if we divide the pitch into eleven equal parts the space will measure $\frac{6}{11}$

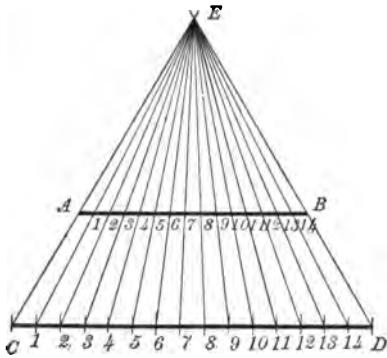

FIG. 27.

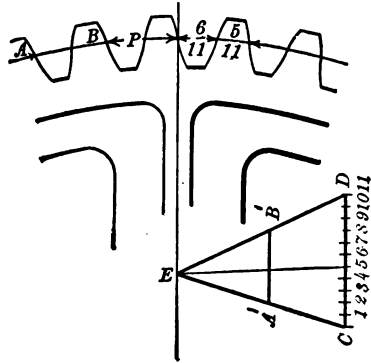

FIG. 28.

and the tooth $\frac{5}{11}$. The $\frac{1}{11}$ which the space is larger than the tooth is called the *backlash*. Let $A'B'$ be the pitch chord of the arc AB . Draw CD parallel to $A'B'$ at any convenient distance and set off on it 11 equal spaces of any convenient length. Draw CA' and DB' intersecting at E . From point 5 draw a line to E which will divide $A'B'$ as required; the one part $\frac{5}{11}$ and the other $\frac{6}{11}$.

FIG. 29. TO DIVIDE A GIVEN LINE INTO ANY NUMBER OF EQUAL PARTS: ANOTHER METHOD.—Let AB be the given line. From A draw AC at any angle, and lay off on it the required number of equal spaces of any convenient length. Join CB and through the divisions on AC draw lines parallel to CB , dividing AB as required in the points $1', 2', 3', 4'$, etc.

FIG. 30. TO DIVIDE A LINE AB PROPORTIONALLY TO THE DIVIDED LINE CD .—Draw AB parallel to CD at any

distance from it. Draw lines through CA and DB and produce them till they meet at E . Draw lines from E through the divisions 1, 2, 3, 4, etc., of line CD , cutting line AB in the

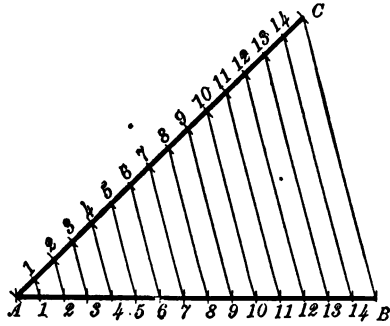

FIG. 29.

points 5, 6, 7, 8, etc. The divisions on AB will have the same proportion to the divisions on CD that the whole line AB has to the whole line CD —i.e., the lines will be proportionally divided.

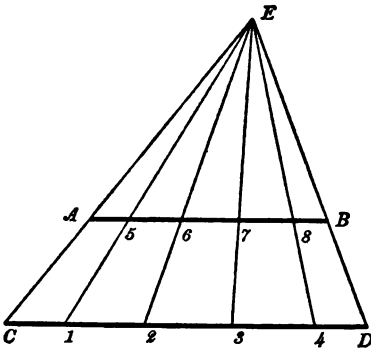

FIG. 30.

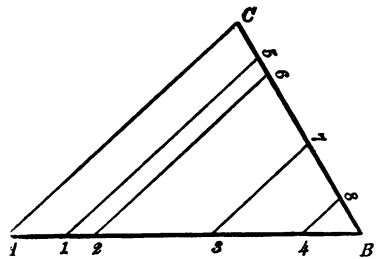

FIG. 31.

FIG. 31. THE SAME: ANOTHER METHOD.—Let BC , the divided line, make any angle with BA , the line to be di-

vided at B . Draw line CA joining the two ends of the lines. Draw lines from 5, 6, 7, 8, parallel to CA , dividing line AB in points 1, 2, 3, 4, proportional to BC .

FIG. 32. TO CONSTRUCT AN EQUILATERAL TRIANGLE ON A GIVEN BASE AB .—From the points A and B with AB as radius describe arcs cutting in C . Draw lines AC and BC . The triangle ABC is equilateral and equiangular.

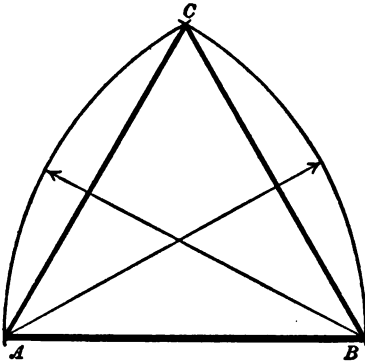

FIG. 32.

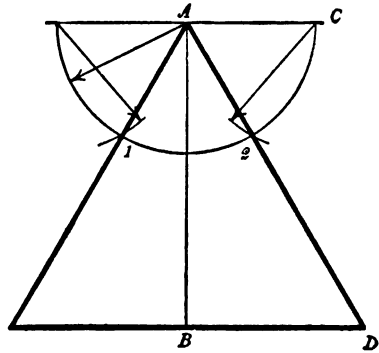

FIG. 33.

FIG. 33. TO CONSTRUCT AN EQUILATERAL TRIANGLE OF A GIVEN ALTITUDE, AB .—From both ends of AB draw lines perpendicular to it as CA and DB . From A with any radius describe a semicircle on CA and with its radius cut off arcs 1, 2. Draw lines from A through 1, 2, and produce them until they cut the base BD .

FIG. 34. TO TRISECT A RIGHT ANGLE ABC .—From the angular point B with any convenient radius describe an arc cutting the sides of the angle in C and A . From C and A with the same radius cut off arcs 1 and 2. Draw lines $1B$ and $2B$, and the right angle will be trisected.

FIG. 35. TO CONSTRUCT ANY TRIANGLE, ITS THREE SIDES AB AND C BEING GIVEN.—From one end of the base as A describe an arc with the line B as radius. From the other end with line C as radius describe an arc, cutting the first arc in D . From D draw lines to the ends of line A , and a triangle will be constructed having its sides equal to the sides given. To construct any triangle the two shorter sides B and C must together be more than equal to the largest side A .

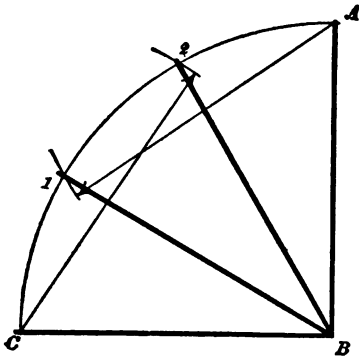

FIG. 34.

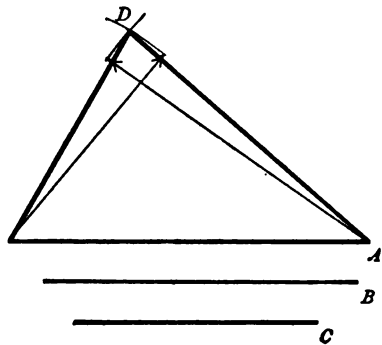

FIG. 35.

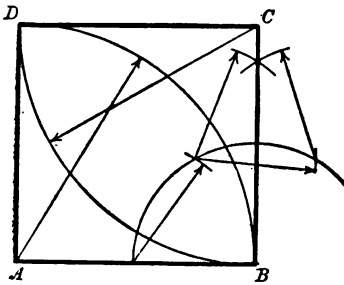

FIG. 36.

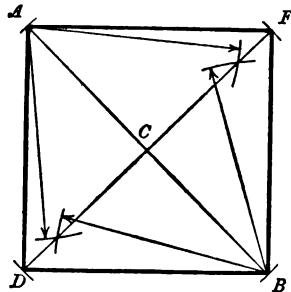

FIG. 37.

FIG. 36. TO CONSTRUCT A SQUARE, ITS BASE AB BEING GIVEN.—Erect a perpendicular at B . Make BC equal

to AB . From A and C with radius AB describe arcs cutting in D . Join DC and DA .

FIG. 37. TO CONSTRUCT A SQUARE, GIVEN ITS DIAGONAL AB .—Bisect AB in C . Draw DF perpendicular to AB at C . Make CD and CF each equal to CA . Join AD , DB , BF , and FA .

X FIG. 38. TO CONSTRUCT A REGULAR POLYGON OF ANY NUMBER OF SIDES, THE CIRCUMSCRIBING CIRCLE BEING GIVEN.—At any point of contact, as C , draw a tangent AB to the given circle. From C with any radius describe a semicircle cutting the given circle. Divide the semicircle into as many equal parts as the polygon is required to have sides, as 1, 2, 3, 4, 5, 6. Draw lines from C through each division, cutting the circle in points which will give the angles of the polygon.

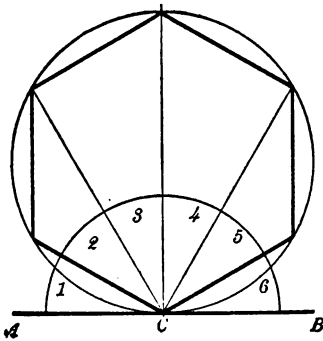

FIG. 38.

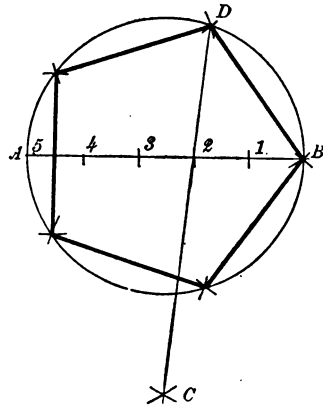

FIG. 39.

X FIG. 39. ANOTHER METHOD.—Draw a diameter AB of the given circle. Divide AB into as many equal parts as the polygon is to have sides, say 5. From A and B with the

line AB as radius describe arcs cutting in C , draw a line from C through the second division of the diameter and produce it cutting the circle in D . BD will be the side of the required polygon. The line C must always be drawn through the second division of the diameter, whatever the number of sides of the polygon.

X FIG. 40. TO CONSTRUCT ANY REGULAR POLYGON WITH A GIVEN SIDE AB .—Make BD perpendicular and equal to AB . With B as center and radius AB describe arc DA . Divide arc DA into as many equal parts as there are sides in the required polygon, as 1, 2, 3, 4, 5. Draw $B2$. Bisect line AB and erect a perpendicular at the bisection cutting $B2$ in C . With C as center and radius CB describe a circle. With AB as a chord step off the remaining sides of the polygon.

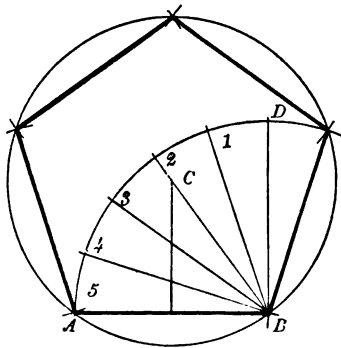

FIG. 40.

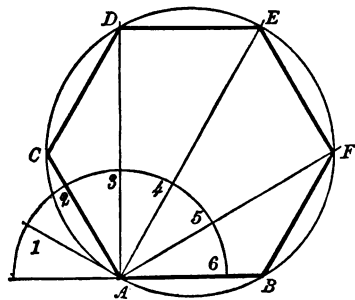

FIG. 41.

X FIG. 41. ANOTHER METHOD.—Extend line AB . With center A and any convenient radius describe a semicircle. Divide the semicircle into as many equal parts as there are sides in the required polygon, say 6. Draw lines through every division except the first. With A as center and AB as

radius cut off A_2 in C . From C with the same radius cut A_3 in D . From D , A_4 in E . From B , A_5 in F . Join AC , CD , DE , EF , and FB .

FIG. 42. TO CONSTRUCT A REGULAR HEPTAGON, THE CIRCUMSCRIBING CIRCLE BEING GIVEN.—Draw a radius AB . With B as center and BA as radius, cut the circumference in 1 , 2 ; it will be bisected by the radius in C . $C1$ or $C2$ is equal to the side of the required heptagon.

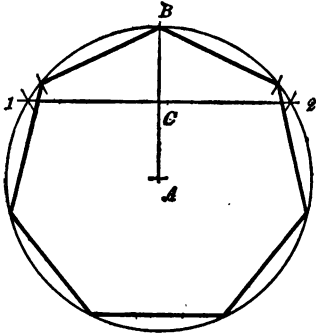

FIG. 42.

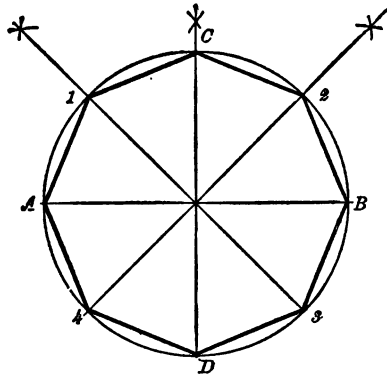
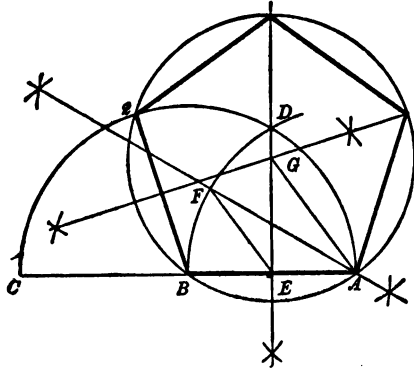

FIG. 43.

FIG. 43. TO CONSTRUCT A REGULAR OCTAGON, THE CIRCUMSCRIBING CIRCLE BEING GIVEN.—Draw a diameter AB . Bisect the arcs AB in C and D . Bisect arcs CA and CB in 1 and 2 . Draw lines from 1 and 2 through the center of the circle, cutting the circumference in 3 and 4 . Join $A1$, $1C$, $C2$, $2B$, $B3$, etc.

FIG. 44. TO CONSTRUCT A PENTAGON, THE SIDE AB BEING GIVEN.—Produce AB . With B as center and BA as radius, describe arc AD_2 . With center A and same radius, describe an arc cutting the first arc in D . Bisect AB in E .

Draw line DE . Bisect arc BD in F . Draw line EF . With center C and radius EF cut off arc $C1$ and $1, 2$ on the semi-circle. Draw line $B2$; it will be a second side of the penta-



• FIG. 44.

gon. Bisect it and draw a line perpendicular to it at the bisection. The perpendiculars from the sides AB and $B2$ will cut in G . With G as center and radius GA describe a circle: it will contain the pentagon.

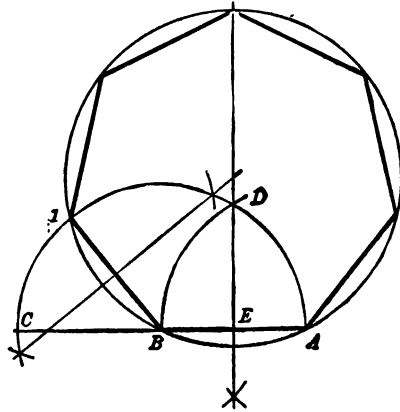

FIG. 45.

FIG. 45. TO CONSTRUCT A HEPTAGON ON A GIVEN LINE AB .—Extend line AB to C . From B with radius AB describe a semicircle. With center A and same radius describe an arc cutting the semicircle in D . Bisect AB in E . Draw line DE . With C as center and DE as radius, cut off arc 1 on the semicircle. Draw line $B1$; it is a second side of the heptagon. Bisect it and obtain the center of the circumscribing circle as in the preceding problem.

FIG. 46. TO INSCRIBE AN OCTAGON IN A GIVEN SQUARE.—Draw diagonals AD , CB intersecting at O . From A , B , C , and D with radius equal to AO describe quadrants cutting the sides of the square in 1, 2, 3, 4, 5, 6, 7, 8. Join these points and the octagon will be inscribed.

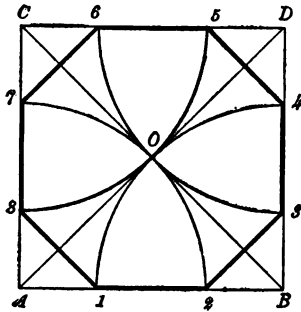

FIG. 46.

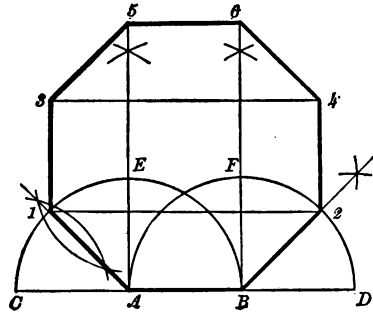

FIG. 47.

FIG. 47. TO CONSTRUCT A REGULAR OCTAGON ON A GIVEN LINE AB .—Extend line AB in both directions. Erect perpendiculars at A and B . With centers A and B and radius AB describe the semicircle CEB and $AF2$. Bisect the quadrants CE and DF in 1 and 2, then $A1$ and $B2$ will be two more sides of the octagon. At 1 and 2 erect perpendiculars 1, 3 and 2, 4 equal to AB . Draw 1-2 and 3-4. Make the

perpendiculars at A and B equal to 1-2 or 3-4—viz., $A5$ and $B6$. Complete the octagon by drawing 3-5, 5-6, and 6-4.

FIG. 48. TO DRAW A RIGHT LINE EQUAL TO HALF THE CIRCUMFERENCE OF A GIVEN CIRCLE.—Draw a diameter AB . Draw line AC perpendicular to AB and equal to three times the radius of the circle. Draw another perpendicular at B to AB . With center B and radius of the circle cut off arc BD , bisect it and draw a line from the center of the circle through the bisection, cutting line B in E . Join EC . Line EC will be equal to half the circumference of circle A .

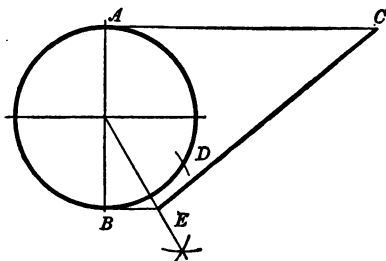

FIG. 48.

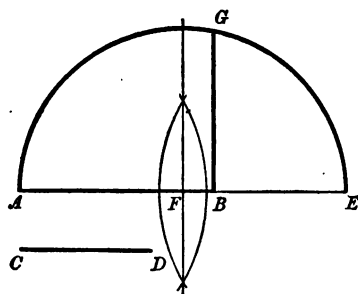

FIG. 49.

FIG. 49. TO FIND A MEAN PROPORTIONAL TO TWO GIVEN RIGHT LINES.—Extend the line AB to E making BE equal to CD . Bisect AE in F . From F with radius FA describe a semicircle. At B where the two given lines are joined erect a perpendicular to AE cutting the semicircle in G . BG will be a mean proportional to CD and AB .

FIG. 50. TO FIND A THIRD PROPORTIONAL (LESS) TO TWO GIVEN RIGHT LINES AB AND CD .—Make EF = the given line AB . Draw EG making an angle with $EF = DC$. Join FG . From E with EG as radius cut EF in H . Draw

H parallel to FG , cutting EG in I . EI is the third proportional (less) to the two given lines.

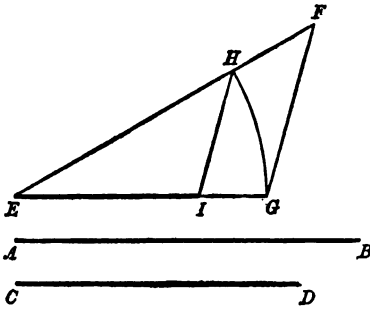

FIG. 50.

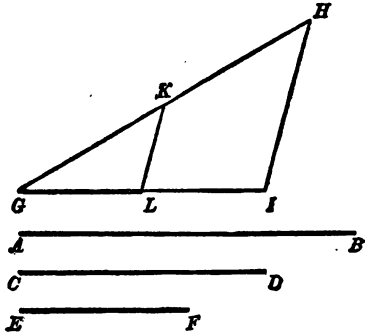

FIG. 51.

FIG. 51. TO FIND A FOURTH PROPORTIONAL TO THREE GIVEN RIGHT LINES AB , CD , AND EF .—Make GH the given line AB . Draw $GI = CD$, making any convenient angle to GH . Join HI . From G lay off $GH = EF$. From K draw a parallel to HI cutting GI in L . GL is the fourth proportional required.

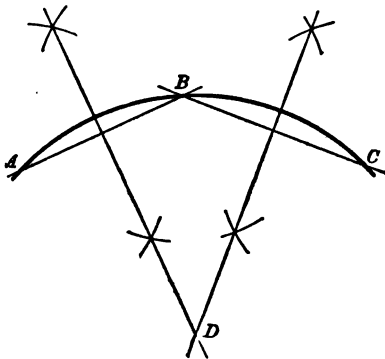

FIG. 52.

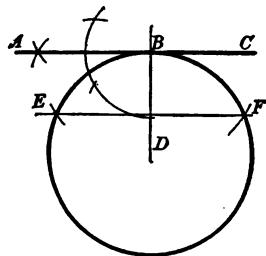

FIG. 53.

FIG. 52. TO FIND THE CENTER OF A GIVEN ARC ABC . —Draw the chords AB and CD and bisect them. Extend the bisection lines to intersect in D the center required.

FIG. 53. TO DRAW A LINE TANGENT TO AN ARC OF A CIRCLE.—(1st.) When the center is not accessible. Let B be the point through which the tangent is to be drawn. From B lay off equal distances as BE , BF . Join EF and through B draw ABC parallel to EF . (2d.) When the center D is given. Draw BD and through B draw ABC perpendicular to BD . ABC is tangent to the circle at the point B .

FIG. 54. TO DRAW TANGENTS TO THE CIRCLE C FROM THE POINT A WITHOUT IT.—Draw AC and bisect it in E . From E with radius EC describe an arc cutting circle C in B and D . Join CB , CD . Draw AB and AD tangent to the circle C .

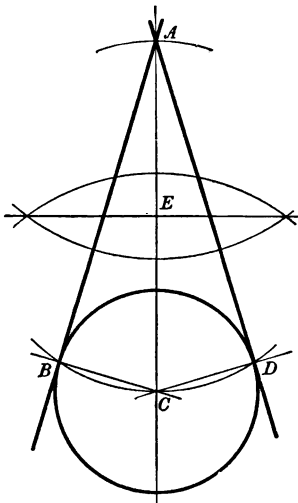

FIG. 54.

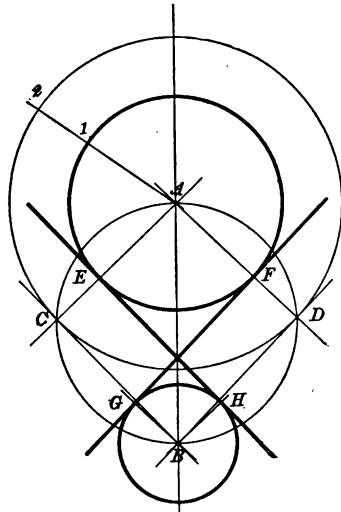

FIG. 55.

FIG. 55. TO DRAW A TANGENT BETWEEN TWO CIRCLES.—Join the centers A and B . Draw any radial line from A as $A2$ and make $1-2 =$ the radius of circle B . From A with radius $A-2$ describe a circle $C2D$. From center B

draw tangents BC and BD to circle C_2D at the points C and D by preceding problem. Join AC and AD and through the points E and F draw parallels FG and EH to BD and BC . FG and EH are the tangents required.

FIG. 56. TO DRAW TANGENTS TO TWO GIVEN CIRCLES A AND B .—Join A and B . From A with a radius equal to the difference of the radii of the given circles de-

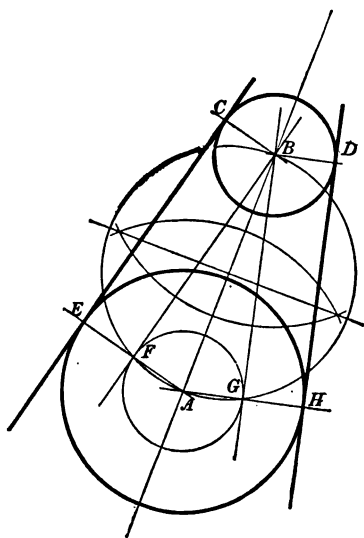

FIG. 56.

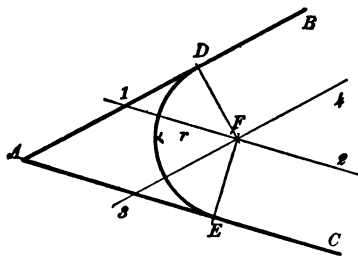

FIG. 57.

scribe a circle GF . From B draw the tangents BF and BG , by Prob. 37. Draw AF and AG extended to E and H . Through E and H draw EC and HD parallel to BF and BG respectively. EC and DH are the tangents required.

FIG. 57. TO DRAW AN ARC OF A CIRCLE OF GIVEN RADIUS TANGENT TO TWO STRAIGHT LINES.— AB and AC are the two straight lines, and r the given radius. At a distance $= r$ draw parallels 1-2 and 3-4 to AC and AB , inter-

secting at F . From F draw perpendiculars FD and FE . With F as center and FD or FE as radius describe the required arc, which will be tangent to the two straight lines at the points D and E .

FIG. 58. TO DRAW AN ARC OF A CIRCLE TANGENT TO TWO STRAIGHT LINES BC and CD WHEN THE MID-POSITION G IS GIVEN.—Draw CA the bisection of the angle BCD and EF at right angles to it through the given point G . Next bisect either of the angles FEB or efd . The bisection line will intersect the central line CA at A , which will be the center of the arc. From A draw perpendiculars $A1$ and $A2$, and with either as a radius and A as center describe an arc which will be tangent to the lines BC and CD at the points 1 and 2 .

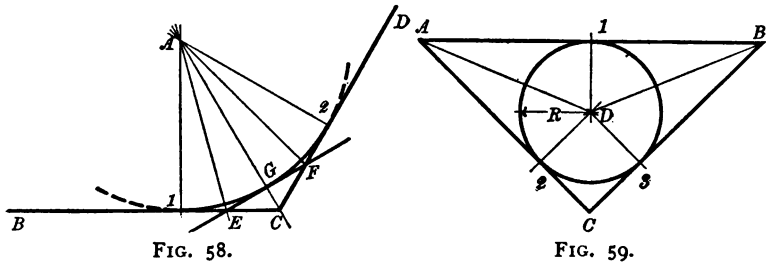

FIG. 59. TO INSCRIBE A CIRCLE WITHIN A TRIANGLE ABC .—Bisect the angles A and B . The bisectors will meet in D . Draw DI perpendicular to AB . Then with center D and radius = DI describe a circle which will be tangent to the given triangle at the points $1, 2, 3$.

FIG. 60. TO DRAW AN ARC OF A CIRCLE OF GIVEN RADIUS R TANGENT TO TWO GIVEN CIRCLES A AND B .—From A and B draw any radial lines as $A3, B4$. Outside the circumference of each circle cut off distances $1-3$ and $2-4$

each = the given radius R . Then with center A and radius $A-3$, and center B and radius $B-4$ describe arcs intersecting at C . Draw CA, CB cutting the circles at 5 and 6. With centre C and radius $C5$ or $C6$ describe an arc which will be tangent at points 5 and 6.

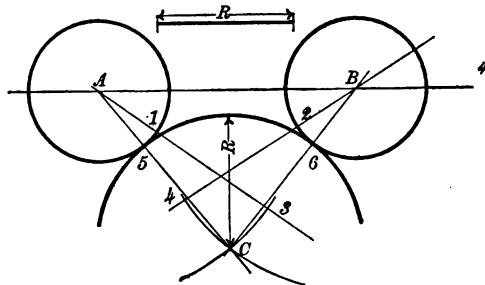

FIG. 60.

FIG. 61. TO DRAW AN ARC OF A CIRCLE OF GIVEN RADIUS R TANGENT TO TWO GIVEN CIRCLES A AND B

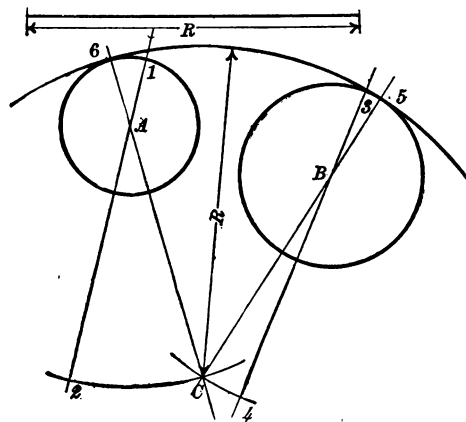

FIG 61.

WHEN THE ARC INCLUDES THE CIRCLES.—Through A and B draw convenient diameters and extend them indefinitely. On

these measure off the distances 1-2 and 3-4, each equal in length to the given radius R . Then with center A and radius $A2$, center B and radius $B4$, describe arcs cutting at C . From C draw $C5$ and $C6$ through B and A . With center C and radius $C6$ or $C5$ describe the arc 6, 5, which will be tangent to the circles at the points 6 and 5.

FIG. 62. TO DRAW AN ARC OF A CIRCLE OF GIVEN RADIUS R TANGENT TO TWO GIVEN CIRCLES A AND B WHEN THE ARC INCLUDES ONE CIRCLE AND EXCLUDES THE OTHER.—Through A draw any diameter and make $1-2 = R$.

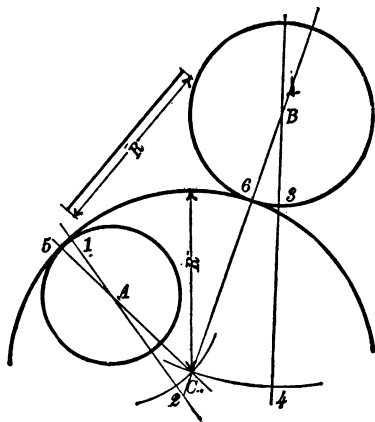

FIG. 62.

From B draw any radius and extend it, making $3-4 = R$. With center A and radius $A2$ and center B and radius $B4$ describe arcs cutting at C . With C as center and radius $= C5$ or $C6$ describe the arc 5, 6.

FIG. 63. DRAW AN ARC OF A CIRCLE OF GIVEN RADIUS R TANGENT TO A STRAIGHT LINE AB AND A CIRCLE CD .—From E , the center of the given circle, draw an arc of a

circle 1, 2 concentric with CD at a distance R from it, and also a straight line 3, 4 parallel to AB at the same distance R from AB . Draw EO intersecting CD at 5. Draw the perpendicular OB . With center O and radius $O6$ or $O5$ describe the required arc.

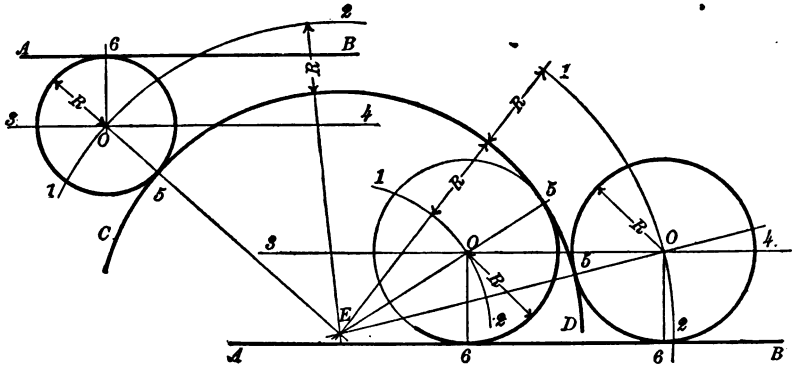

FIG. 63.

FIG. 64. TO DESCRIBE AN ELLIPSE APPROXIMATELY BY MEANS OF THREE RADII (F. R. Honey's method).—

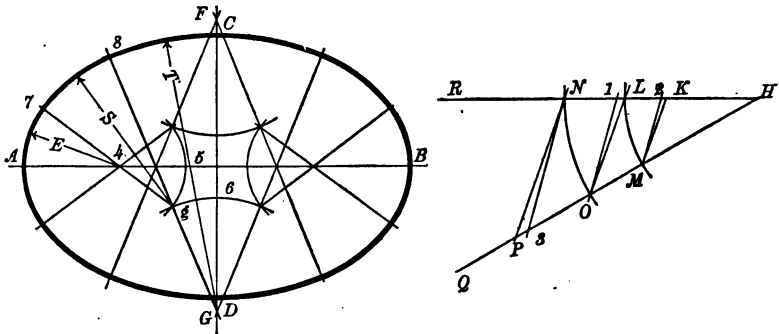

FIG. 64.

Draw straight lines RH and HQ , making any convenient angle at H . With center H and radii equal to the semi-minor and

semi-major axes respectively, describe arcs LM and NO . Join LO and draw MK and NP parallel to LO . Lay off $L1 = \frac{1}{2}$ of LN . Join $O1$ and draw $M2$ and $N3$ parallel to $O1$. Take $H3$ for the longest radius ($= T$), $H2$ for the shortest radius ($= E$), and one-half the sum of the semi-axes for the third radius ($= S$), and use these radii to describe the ellipse as follows: Let AB and CD be the major and minor axes. Lay off $A4 = E$ and $A5 = S$. Then lay off $CG = T$ and $C6 = S$. With G as center and $G6$ as radius draw the arc 6, g . With center 4 and radius 4, 5, draw arc 5, g , intersecting 6, g at g . Draw the line Gg and produce it making $G8 = T$. Draw g , 4 and extend it to 7 making g , 7 = S . With center G and radius $GC (= T)$ draw the arc $C8$. With center g and radius g , 8 ($= S$) draw the arc 8, 7. With center 4 and radius 4, 7 ($= E$) draw arc 7A. The remaining quadrants can be drawn in the same way.

FIG. 65. TO DRAW AN ELLIPSE HAVING GIVEN THE AXES AB AND CD .—Draw AB and CD at right angles to and bisecting each other at E . With center C and radius EA cut AB in F and F' the foci. Divide EF or EF' into a number of parts as shown at 1, 2, 3, 4, etc. Then with F and F' as cen-

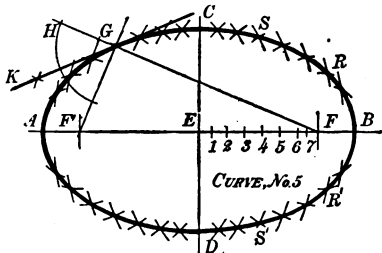

FIG. 65.

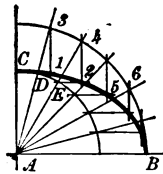

FIG. 66.

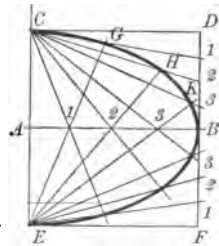

FIG. 67.

ters and $A1$ and $B1$, and $A2$ and $B2$, etc., as radii describe arcs intersecting in R , S , etc., until a sufficient number of points

are found to draw the elliptic curve accurately throughout. (No. 5 of the "Sibley College Set" of irregular curves is very useful in drawing this curve.) To draw a tangent to the ellipse at the point G : Extend FG and draw the bisector of the angle HGF' . KG is the tangent required.

FIG. 66. ANOTHER METHOD.—Let AB and AC be the semi axes. With A as center and radii AB and AC describe circles. Draw any radii as A_3 and A_4 , etc. Make $3\ 1$, $4\ 2$, etc., perpendicular to AB , and D_2 , E_5 , etc., parallel to AB . Then 1 , 2 , 5 , etc., are points on the curve.

FIG. 67. ANOTHER METHOD.—Place the diameters as before, and construct the rectangle $CDEF$. Divide AB and DB and BF into the same number of equal parts as 1 , 2 , 3 and B . Draw from C through points 1 , 2 , 3 on AB and BD lines to meet others drawn from E through points 1 , 2 , 3 on AB and FB intersecting in points G , H , K . G , H , K are points on the curve.

FIG. 68. ANOTHER METHOD.—Place the diameters AB and CD as shown in Drawing No. 1. Draw any convenient

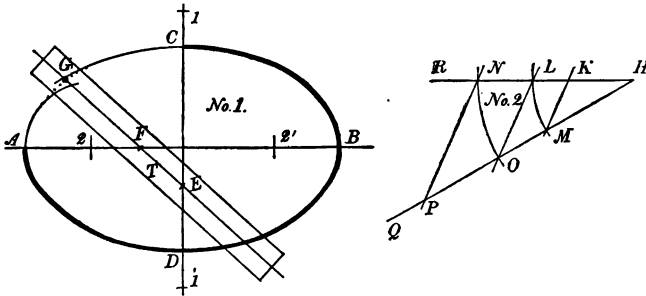

FIG. 68.

angle RHQ , Drawing No. 2. With center H and radii equal to the semi-minor and semi-major axes describe arcs LM and

NO. Join LO and draw MK and NP parallel to LO . Then from C and D with a distance = HP lay off the points 1 $1'$ on the minor axis and from A and B with a distance = HK lay off the points 2 $2'$ on the major axis. With centers $1, 1', 2$ and $2'$ and radii $1-D$ and $2-B$, respectively, draw arcs of circles. On a piece of transparent celluloid T lay off from the point G , GF and $GE =$ the semi-minor and semi-major axes respectively. Place the point F on the major axis and the point E on the minor axis. If the strip of celluloid is now moved over the figure, so that the point E is always in contact with the semi-minor axis and the point F with the semi-major axis, the necessary number of points may be marked through a small hole in the celluloid at G with a sharp conical-pointed pencil, and thus complete the curve of the ellipse between the arcs of circles.

FIG. 69. TO CONSTRUCT A PARABOLA, THE BASE CD AND THE ABSCISSA AB BEING GIVEN.—Draw EF through A parallel to CD and CE and DF parallel to AB . Divide AE , AF , EC , and FD into the same number of equal parts. Through the points $1, 2, 3$ on AF and AE draw lines parallel to AB , and through A draw lines to the points $1, 2, 3$ on FD and EC intersecting the parallel lines in points $4, 5, 6$, etc., of the curve.

FIG. 70. GIVEN THE DIRECTRIX BD AND THE FOCUS C TO DRAW A PARABOLA AND A TANGENT TO IT AT THE POINT 3 .—The parabola is a curve such that every point in the curve is equally distant from the directrix BD and the focus C . The vertex E is equally distant from the directrix and the focus, i.e. CE is = EB . Any line parallel to the axis is a diameter. A straight line drawn across the figure at right angles to the

axis is a double ordinate, and either half of it is an ordinate. The distance from C to any point upon the curve, as 2 is always equal to the horizontal distance from that point to the directrix. Thus $C1 = 1, 1', C2$ to $2, 2',$ etc. Through C draw ACF at right angles to BD , ACF is the axis of the

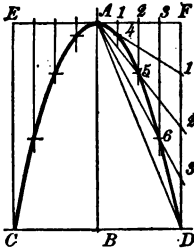

FIG. 69.

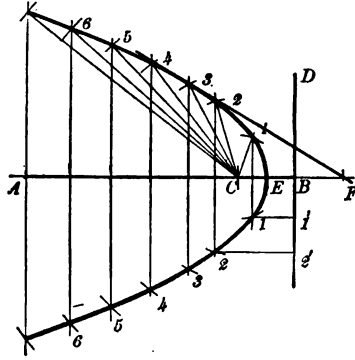

FIG. 70.

curve. Draw parallels to BD through any points in AB , and with center C and radii equal to the horizontal distances of these parallels from BD describe arcs cutting in the points 1, 2, 3, 4, etc. These are points in the curve. The tangent to the curve at the point 3 may be drawn as follows: Produce AB to F . Make $EF =$ the horizontal distance of ordinate 33 from E . Draw the tangent through $3F$.

FIG. 71. TO DRAW AN HYPERBOLA, HAVING GIVEN THE DIAMETER AB , THE ABSCISSA BD , AND DOUBLE ORDINATE EF .—Make $F4$ parallel and equal to BD . Divide DF and $F4$ into the same number of equal parts. From B draw lines to the points in $4F$ and from A draw lines to the points in DF . Draw the curve through the points where the lines correspondingly numbered intersect each other.

FIG. 72. TO CONSTRUCT AN OVAL THE WIDTH AB BEING GIVEN.—Bisect AB by the line CD in the point E , and with E as center and radius EA draw a circle cutting CD in

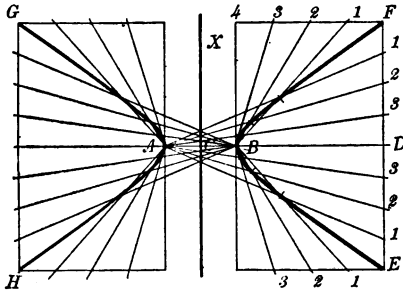

FIG. 71.

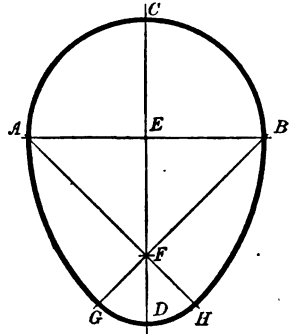

FIG. 72.

F . From A and B draw lines through F . From A and B with radius equal to AB draw arcs cutting the last two lines in G and H . From F with radius FG describe the arc GH to meet the arcs AG and BH , which will complete the oval.

FIG. 73. GIVEN AN ELLIPSE TO FIND THE AXES AND FOCI.—Draw two parallel chords AB and CD . Bisect each of these in E and F . Draw EF touching the ellipse in 1 and 2. This line divides the ellipse obliquely into equal parts. Bisect 1, 2 in G , which will be the center of the ellipse. From G with any radius draw a circle cutting the ellipse in H, I, J, K . Join these four points and a rectangle will be formed in the ellipse. Lines LM and NO , bisecting the sides of the rectangle, will be the diameters or axes of the ellipse. With N or O as centers and radius = GL the semi-major axis, describe arcs cutting the major axis in P and Q the foci.

FIG. 74. TO CONSTRUCT A SIPRAL OF ONE REVOLUTION.—Describe a circle using the widest limit of the spiral as

a radius. Divide the circle into any number of equal parts as *A, B, C*, etc. Divide the radius into the same number of equal parts as 1 to 12. From the center with radius 12, 1 describe an arc cutting the radial line *B* in *1'*. From the center continue to draw arcs from points 2, 3, 4, etc., cutting the corresponding radii *C, D, E*, etc. in the points *2', 3', 4'*, etc. From 12 trace the Archimedes Spiral of one revolution.

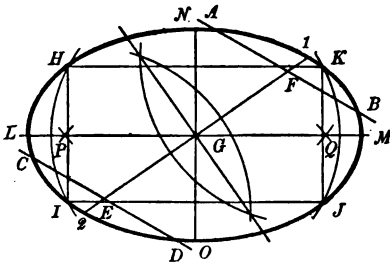

FIG. 73.

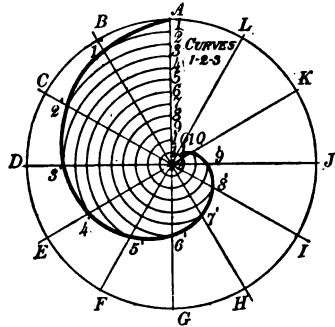

FIG. 74.

FIG. 75. TO DESCRIBE A SPIRAL OF ANY NUMBER OF REVOLUTIONS, E.G., 2.—Divide the circle into any number of equal parts as *A, B, C*, etc., and draw radii. Divide the radius *A12* into a number of equal parts corresponding with the required number of revolutions and divide these into the same number of equal parts as there are radii, viz., 1 to 12. It will be evident that the figure consists of two separate spirals, one from the center of the circle to 12, and one from 12 to *A*. Commence as in the last problem, drawing arcs from 1, 2, 3, etc., to the correspondingly numbered radii, thus obtaining the points marked *1', 2', 3'*, etc. The first revolution completed, proceed in the same manner to find the points *1'', 2'', 3''*, etc. Through these points trace the spiral of two revolutions.

FIG. 76. TO CONSTRUCT THE INVOLUTE OF THE CIRCLE *O*.—Divide the circle into any number of equal parts and draw radii. Draw tangents at right angles to these radii. On the tangent to radius 1 lay off a distance equal to one of the parts into which the circle is divided, and on each of

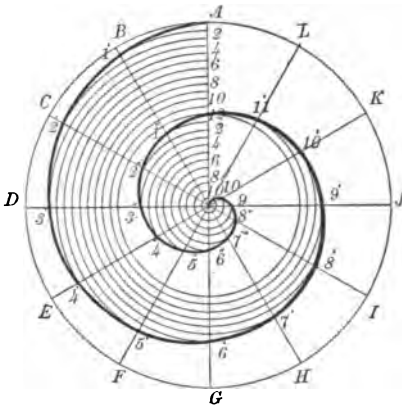

FIG. 75.

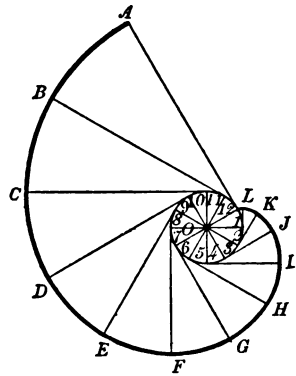

FIG. 76.

the tangents set off the number of parts corresponding to the number of the radii. Tangent 12 will then be the circumference of the circle unrolled, and the curve drawn through the extremities of the other tangents will be the involute.

FIG. 77. TO DESCRIBE AN IONIC VOLUTE.—Divide the given height into seven equal parts, and through the point 3 the upper extremity of the third division draw 3, 3 perpendicular to *AB*. From any convenient point on 33 as a center, with radius equal to one-half of one of the divisions on *AB*, describe the eye of the volute *NPNM*, shown enlarged at Drawing No. 2. *NN* corresponds to line 3, 3, Drawing No. 1. Make *PM* perpendicular to *NN* and inscribe the square *NPNM*, bisect its sides and draw the square 11, 12,

13, 14. Draw the diagonals 11, 13 and 12, 14 and divide them as shown in Drawing No. 2. At the intersections of the horizontal with the perpendicular full lines locate the points 1, 2, 3, 4, etc., which will be the centers of the quadrants of the outer curve. The centers for the inner curve will be found at the intersections of the horizontal and per-

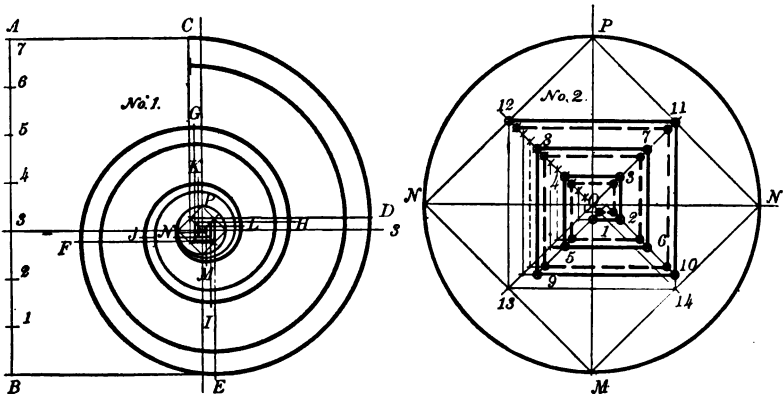

FIG. 77.

pendicular broken lines, drawn through the divisions on the diagonals. Then with center 1 and radius $1P$ draw arc PN , and with center 2 and radius $2N$ draw arc NM , with center 3 and radius $3M$ draw arc ML , etc. The inner curve is drawn in a similar way, by using the points on the diagonals indicated by the broken lines as centers.

FIG. 78. TO DESCRIBE THE CYCLOID.— AB is the director, CB the generating circle, X a piece of thin transparent celluloid, with one side dull on which to draw the circle C . At any point on the circle C puncture a small hole with a sharp needle, and place the point C tangent to the director AB at the point from which the curve is to be drawn. Hold the celluloid at this point with a needle, and rotate it until

the arc of the circle C intersects the director AB . Through the point of intersection stick another needle and rotate X until the circle is again tangent to AB , and through the puncture at C with a 4H pencil, sharpened to a fine conical point, mark the first point on the curve. So proceed until sufficient points have been found to complete the curve.

(NOTE.—The thin celluloid was first used as a drawing instrument by Professor H. D. Williams, of Sibley College, Cornell University.)

FIG. 79. TO FIND THE LENGTH OF A GIVEN ARC OF A CIRCLE APPROXIMATELY.—Let BC be the given arc. Draw its chord and produce it to A , making BA equal half the

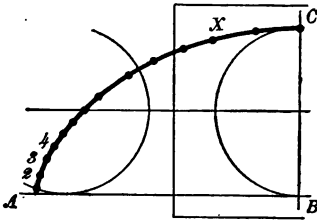

FIG. 78.

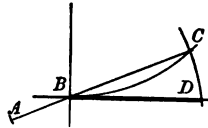

FIG. 79.

chord. With center A and radius AC describe arc CD cutting the tangent line BD at D , and making it equal to the arc BC .

FIG. 80. TO DESCRIBE THE CYCLOID BY THE OLD METHOD.—Divide the director and the generating circle into the same number of equal parts. Through the center a draw ag parallel to AB for the line of centers, and divide it as AB in the points b, c, d, e, f , and g . With centers f, e, d , etc., describe arcs tangent to AB , and through the points of division on the generating circle $1, 2, 3$, etc., draw lines parallel to

AB cutting the arcs in the points $1', 2', 3'$, etc. These will be points in the curve.

An approximate curve may be drawn by arcs of circles. Thus, taking f' as center and $f'g'$ as radius, draw arc $g'1'$.

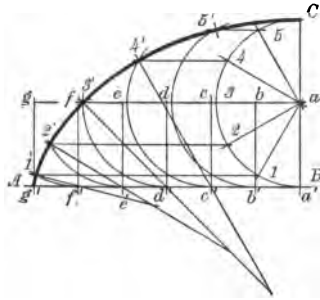

FIG. 80.

Produce $1'f'$ and $2'e'$ until they meet at the center of the second arc $2'f'$, etc.

FIG. 81. TO DESCRIBE THE EPICYCLOID AND THE HYPOCYCLOID.—Divide the generating circle into any number of equal parts, 1, 2, 3, etc., and set off these lengths from C on the directing circle CB as e', d', c' , etc. From A the center of the directing circle draw lines through e', d', c' , etc., cutting the circles of centers in e, d, c , etc. From each of these points as centers describe arcs tangent to the directing circle. From center A draw arcs through the points of division on the generating circle, cutting the arcs of the generating circles in their several positions at the points $1', 2', 3'$, etc. These will be points in the curve.

FIG. 82. ANOTHER METHOD.—Draw the generating circle on the celluloid and roll it on the outside of the generating circle BC for the Epicycloid, and on the inside for the

Hypocycloid, marking the points in the curve 1, 2, 3, etc., in similar manner to that described for the Cycloid.

FIG. 82.

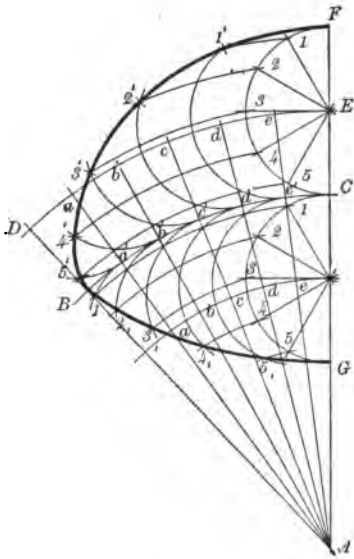

FIG. 81.

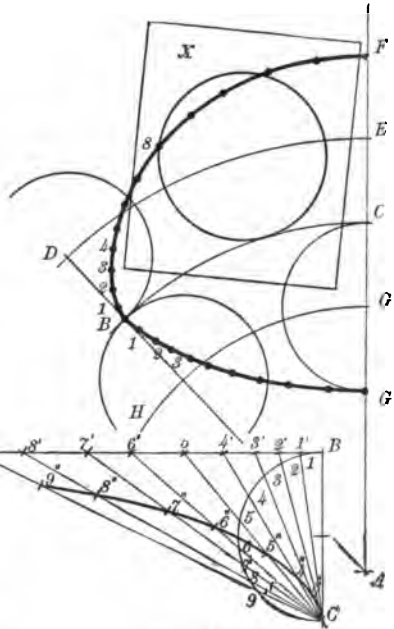

FIG. 83.

FIG. 83. TO DRAW THE CISSOID.—Draw any line AB and BC perpendicular to it. On BC describe a circle. From the extremity C of the diameter draw any number of lines, at any distance apart, passing through the circle and meeting the line AB in $1', 2', 3',$ etc. Take the length from A to 9 and set it off from C on the same line to $9''$. Take the distance from $8'$ to 8 and set it off from C on the same line to $8''$, etc., for the other divisions, and through $9'', 8'', 7'', 6'',$ etc., draw the curve.

FIG. 84. TO DRAW SCHIELE'S ANTI-FRICTION CURVE.—Let AB be the radius of the shaft and $B1, 2, 3, 4$, etc., its axis. Set off the radius AB on the straight edge of a piece of stiff paper or thin celluloid and placing the point B on the division 1 of the axis, draw through point A the line $A1$. Then lower the straight edge until the point B coincides with 2 and the point A just touches the last line drawn, and draw $a2$, and so proceed to find the points a, b, c , etc. Through these points draw the curve.

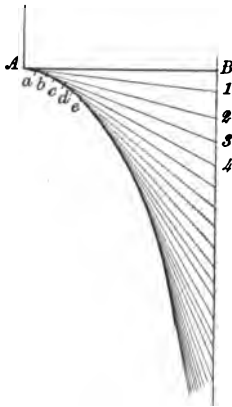

FIG. 84.

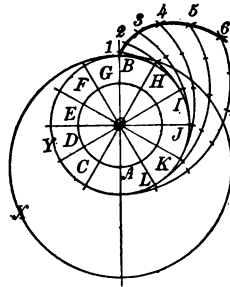

FIG. 85.

FIG. 85. TO DESCRIBE AN INTERIOR EPICYCLOID.—Let the large circle X be the generator and the small circle Y the director. Divide circle Y into any number of equal parts, as B, H, I, J , etc. Draw radial lines and make HC, ID, JE, KF , etc., each equal to the radius of the generator X . With centers C, D, E , etc., describe arcs tangent at H, I, J , etc. Make $H1$ equal to one of the divisions of the director as BH . Make $I2$ equal to two divisions, $J3$, three divisions, etc., and draw the curve through the points 1, 2, 3, 4,

etc. This curve may also be described with a piece of celluloid in a similar way to that explained for the cycloid.

It may not be out of place here to describe a few of the

MOULDINGS USED IN ARCHITECTURAL WORK,

since they are often found applied to mechanical constructions.

FIG. 86. TO DESCRIBE THE "SCOTIA."—1, 1 is the top line and 4, 4 the bottom line. From 1 drop a perpendicular 1, 4; divide this into three equal parts, as 1, 2, and 3. Through the point 2 draw ab parallel to 1, 1. With center 2 and radius 2, 1 describe the semicircle $a1b$, and with center b and radius ba describe the arc $a5$ tangent to 4, 4 at 5, draw the fillets 1, 1 and 4, 4.

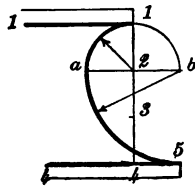

FIG. 86.

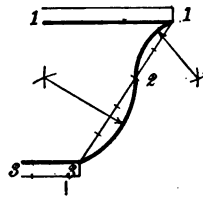

FIG. 87.

FIG. 87. TO DESCRIBE THE "CYMA RECTA."—Join 1, 3 and divide it into five equal parts, bisect 1, 2 and 2, 3, and with radius equal to 1, 2 and 2, 3 respectively describe arcs 1, 2 and 2, 3. Draw the fillets 1, 1 and 3, 3 and complete the moulding.

FIG. 88. TO DESCRIBE THE "CAVETTO" OR "HOLLOW."—Divide the perpendicular 1, 2 into three equal parts and make 2, 3 equal to two of these. From centers 1 and 3 with a radius somewhat greater than the half of 1, 3, describe arcs intersecting at the center of the arc 1, 3,

FIG. 89. TO DESCRIBE THE "ECHINUS," "QUARTER ROUND," OR "OVOLO."—Draw 1, 2 perpendicular to 2, 3, and divide it into three equal parts. Make 2, 3 equal to two of these parts. From the points 2 and 3 with a radius greater than half 1, 3, describe arcs cutting in the center of the required curve.

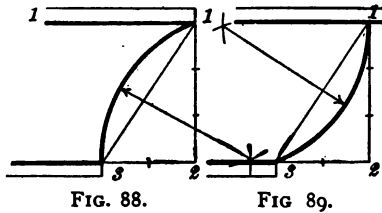

FIG. 90. TO DESCRIBE THE "APOPHYGEE."—Divide 3, 4 into four equal parts and lay off five of these parts from 3 to 2. From points 2 and 4 as centers and radius equal to 2, 3, describe arcs intersecting in the center of the curve.

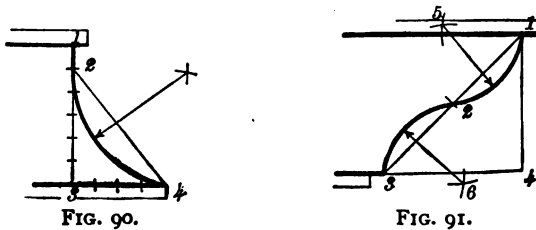

FIG. 91. TO DESCRIBE THE "CYMA REVERSA."—Make 4, 3 = 4, 1. Join 1, 3 and bisect it in the point 2. From the points 1, 2 and 3 as centers and radii equal to about two-thirds of 1, 2 draw arcs intersecting at 5 and 6. Points 5 and 6 are the centers of the reverse curves.

FIG. 92. TO DESCRIBE THE "TORUS."—Let 1, 2 be the breadth. Drop the perpendicular 1, 2, and bisect it in the

point 3. With 3 as center and radius 3, 1, describe the semi-circle. Draw the fillets.

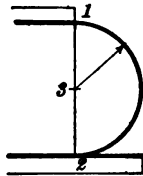

FIG. 92.

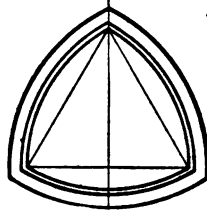

FIG. 93.

FIG. 93. AN ARCHED WINDOW OPENING.—The curves are all arcs of circles, drawn from the three points of the equilateral triangle, as shown in the figure.

FIG. 94. TO DESCRIBE THE “TREFOIL.”—The equilateral triangle is drawn first, and the angle 1, 2, 3 bisected by the line 2, 4, which also cuts the perpendicular line 1, 6 in the point 6. The center of the surrounding circles 1, 2 and 3 are the centers of the trefoil curves.

FIG. 95. TO DESCRIBE THE “QUATRE FOIL.”—Draw the square 1, 2, 3, 4 in the position shown in the figure. The center of the surrounding circles, point 5, is at the intersection of the diagonals of the square. Points 1, 2, 3, 4 of the square are the centers of the small arcs.

FIG. 96. TO DESCRIBE THE “CINQUEFOIL ORNAMENT.” The curves of the cinquefoil are described from the corners of a pentagon 1, 2, 3, 4, 5. Bisect 4, 5 in 6 and draw 2, 6, cutting the perpendicular in the point 7, the center of the large circles.

FIG. 97. TO DRAW A BALUSTER.—Begin by drawing the center line, and lay off the extreme perpendicular height,

the intermediate, perpendicular, and horizontal dimensions, and finally the curves as shown in the figure.

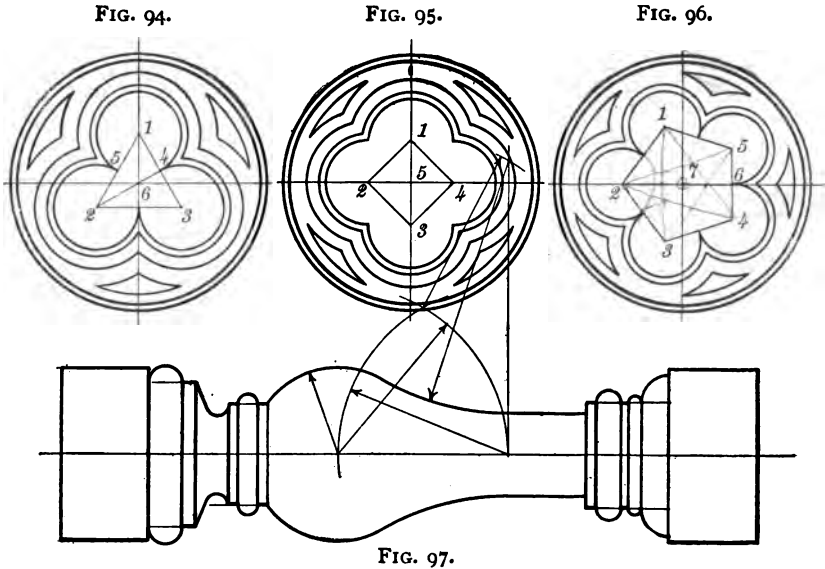

DRAWING TO SCALE.

When we speak of a drawing as having been made to scale, we mean that every part of it has been drawn proportionately and accurately, either *full size*, *reduced* or *enlarged*.

Very small and complicated details of machinery are usually drawn enlarged; larger details and small machines may be made full size, while larger machines and large details are shown reduced.

When a drawing of a machine is made to a reduced or enlarged scale the figures placed upon it should always give the full-size dimensions, i.e., the sizes the machine should measure when finished.

FIG. 98. TO CONSTRUCT A SCALE OF THIRD SIZE OR $4'' = 1$ FOOT.—Draw upon a piece of tough white drawing-paper two parallel lines about $1''$ apart and about $14''$ long as shown by *a*, Fig. 98. From *A* lay off distances equal to $4''$ and divide the first space *AB* into 12 equal parts or inches by Prob. 12. Divide *AE* in the same way into as many parts as it may be desired to subdivide the inch divisions on *AB*,

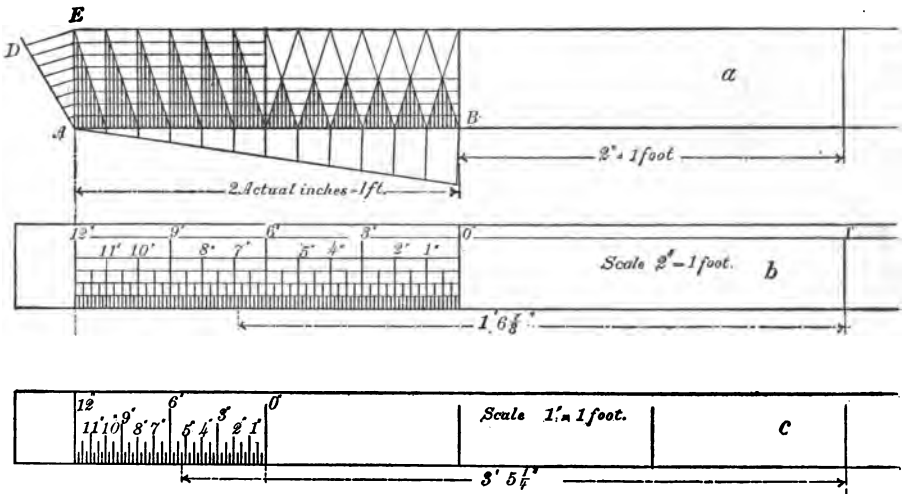

FIG. 98.

usually 8. When the divisions and subdivisions have been carefully and lightly drawn in pencil, as shown by *a*, in Fig. 98, then the lines denoting $\frac{1}{8}''$, $\frac{1}{4}''$, $\frac{1}{2}''$, $1''$, and $3''$ should be carefully inked and numbered as shown by (*b*). By a further subdivision a scale of $2'' = 1$ foot may easily be made as shown by (*c*) in Fig. 98.

CHAPTER III.

CONVENTIONS.

It is often unnecessary if not undesirable to represent certain things as they would actually appear in a drawing, especially when much time and labor is required to make them orthographically true.

So for economic reasons draftsmen have agreed upon conventional methods to represent many things that would otherwise entail much extra labor and expense, and serve no particular purpose.

It is very necessary, however, that all draftsmen should *know how* to draw these things correctly, for occasions will often arise when such knowledge will be demanded; and besides it gives one a feeling of greater satisfaction when using conventional methods to know that he could make them artistically true if it was deemed necessary.

STANDARD CONVENTIONAL SECTION LINES.

Conventional section lines are placed on drawings to distinguish the different kinds of materials used when such drawings are to be finished in pencil, or traced for blue printing, or to be used for a reproduction of any kind.

Water-colors are nearly always used for finished drawings and sometimes for tracings and pencil drawings.

The color tints can be applied in much less time than it

takes to hatch-line a drawing. So that the color method should be used whenever possible.

FIG. 99.—This figure shows a collection of hatch-lined sections that is now the almost universal practice among draftsmen in this and other countries, and may be considered standard.

No. 1. To the right is shown a section of a wall made of *rocks*. When used without color, as in tracing for printing, the rocks are simply shaded with India ink and a 175 Gillott steel pen. For a colored drawing the ground work is made of gamboge or burnt umber. To the left is the conventional representation of water for tracings. For colored drawings a blended wash of Prussian blue is added.

No. 2. *Convention for Marble*.—When colored, the whole section is made thoroughly wet and each stone is then streaked with Payne's gray.

No. 3. *Convention for Chestnut*.—When colored, a ground wash of gamboge with a little crimson lake and burnt umber is used. The colors for graining should be mixed in a separate dish, burnt umber with a little Payne's gray and crimson lake added in equal quantities and made dark enough to form a sufficient contrast to the ground color.

No. 4. *General Convention for Wood*.—When colored the ground work should be made with a light wash of burnt sienna. The graining should be done with a writing-pen and a dark mixture of burnt sienna and a modicum of India ink.

No. 5. *Convention for Black Walnut*.—A mixture of Payne's gray, burnt umber and crimson lake in equal quantities is used for the ground color. The same mixture is used for graining when made dark by adding more burnt umber.

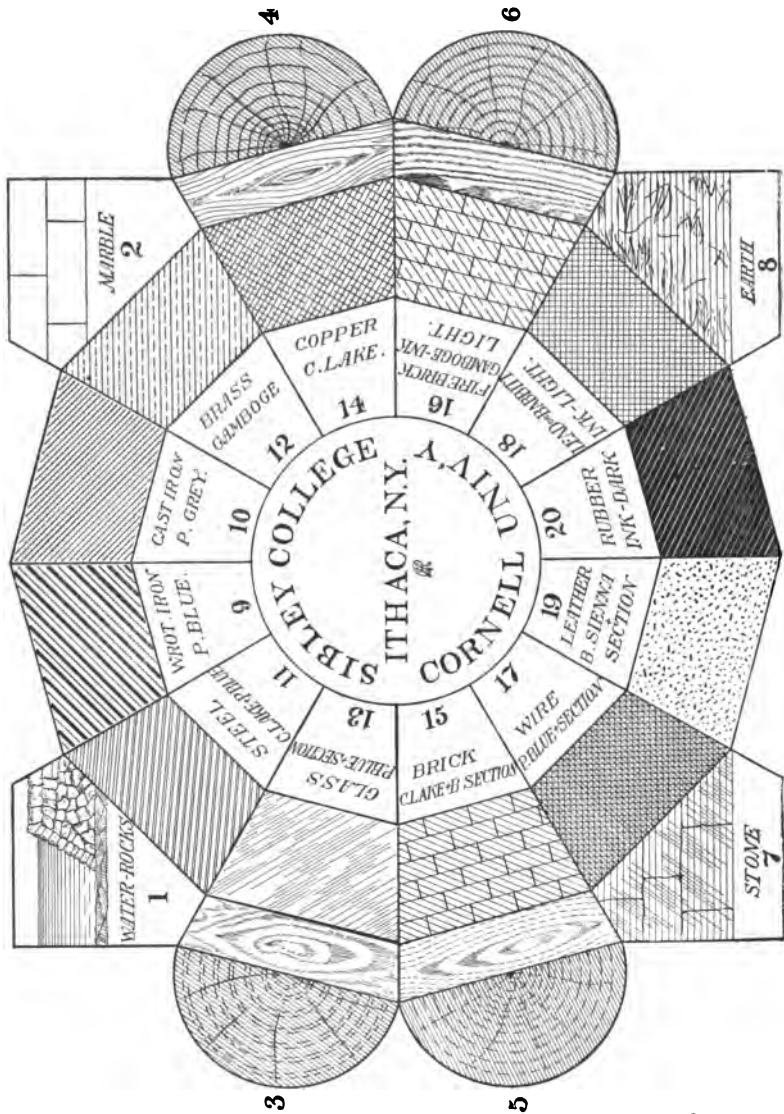

FIG. 99.

No. 6. *Convention for Hard Pine.*—For the ground color make a light wash of crimson lake, burnt umber, and gamboge, equal parts. For graining use a darker mixture of of crimson lake and burnt umber.

No. 7. *Convention for Building-stone.*—The ground color is a light wash of Payne's gray and the shade lines are added mechanically with the drawing-pen or free-hand with the writing-pen.

No. 8. *Convention for Earth.*—Ground color, India ink and neutral tint. The irregular lines to be added with a writing-pen and India ink.

No. 9. *Section Lining for Wrought or Malleable Iron.*—When the drawing is to be tinted, the color used is Prussian blue.

No. 10. *Cast Iron.*—These section lines should be drawn equidistant, not very far apart and narrower than the body lines of the drawing. The tint is Payne's gray.

No. 11. *Steel.*—This section is used for all kinds of steel. The lines should be of the same width as those used for cast-iron and the spaces between the double and single lines should be uniform. The color tint is Prussian blue with enough crimson lake added to make a warm purple.

No. 12. *Brass.*—This section is generally used for all kinds of composition brass, such as gun-metal, yellow metal, bronze metal, Muntz metal, etc. The width of the full lines, dash lines and spaces should all be uniform. The color tint is a light wash of gamboge.

Nos. 13–20.—The section lines and color tints for these numbers are so plainly given in the figure that further instruction would seem to be superfluous.

CONVENTIONAL LINES.

FIG. 100.—There are four kinds:

(1) *The Hidden Line*.—This line should be made of short dashes of uniform length and width, both depending somewhat on the size of the drawing. The width should always be slightly less than the body lines of the drawing, and the

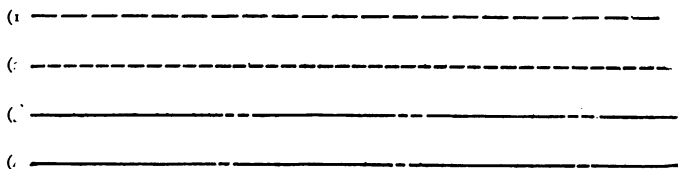

length of the dash should never exceed $\frac{1}{8}$ ". The spaces between the dashes should all be uniform, quite small, never exceeding $\frac{1}{8}$ ". This line is always inked in with *black ink*.

(2) *The Line of Motion*.—This line is used to indicate *point paths*. The dashes should be made shorter than those of the *hidden line*, just a trifle longer than dots. The spaces should of course be short and uniform.

(3) *Center Lines*.—Most drawings of machines and parts of machines are symmetrical about their center lines. When penciling a drawing these lines may be drawn continuous and as fine as possible, but on drawings for reproductions the black-inked line should be a long narrow dash and two short ones alternately. When colored inks are used the center line should be made a continuous *red* line and as fine as it is possible to make it.

(4) *Dimension Lines and Line of Section*.—These lines are made in *black* with a fine long dash and one short dash alternately. In color they should be continuous *blue* lines.

Colored lines should be used wherever feasible, because they are so quickly drawn and when made fine they give the drawing a much neater appearance than when the conventional black lines are used. Colored lines should *never* be broken.

CONVENTIONAL BREAKS.

FIG. 101.—Breaks are used in drawings sometimes to indicate that the thing is actually longer than it is drawn, some-

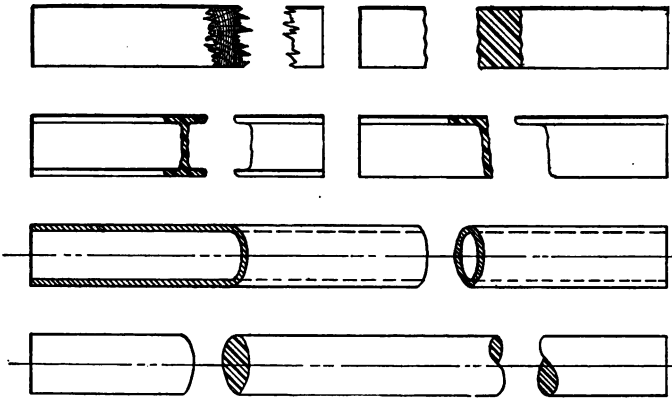

FIG. 101.

times to show the shape of the cross-section and the kind of material. Those given in Fig. 101 show the usual practice.

CROSS-SECTIONS.

FIG. 102.—When a cross-section of a pulley, gear-wheel or other similar object is required and the cutting-plane passes through one of the spokes or arms, then only the rim and hub should be sectioned, as shown at *xx* No. 1 and *zz* No. 2, and the arm or spoke simply outlined. Cross-sections of the arms may be made as shown at *AA* No. 2. In working drawings of

gear-wheels only the number of teeth included in one quadrant need be drawn; the balance is usually shown by conventional lines, e.g., the *pitch* line the same as a center line, viz., a long

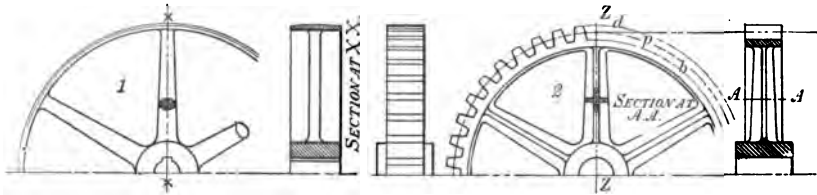

FIG. 102.

dash and two very short ones alternately or a fine continuous *red* line.

The *addendum* line (*d*) and the *root* or *bottom line* (*b*) the same as a dimension line, viz., one long dash and one short dash alternately or a fine continuous *blue* line. The end elevation of the gear-teeth should be made by projecting only the points of the teeth, as shown at No. 2.

CONVENTIONAL METHODS OF SHOWING SCREW-THREADS IN WORKING DRAWINGS.

FIG. 103.—No. 1, shows the convention for a double V thread, U. S. standard; No. 2, a single V thread; No. 3, a single square thread; No. 4, a double left-hand V thread; No. 5, a double right-hand square thread; No. 6, any thread of small diameter; No. 7, any thread of very small diameter. The true methods for constructing these threads are explained on pages 99–101, Figs. 99–101.

In No. 6. the short wide line is equal to the diameter of the thread at the bottom. The distance between the

longer narrow lines is equal to the pitch, and the inclination is equal to half the pitch.

The short dash lines in No. 7 should be made to corre-

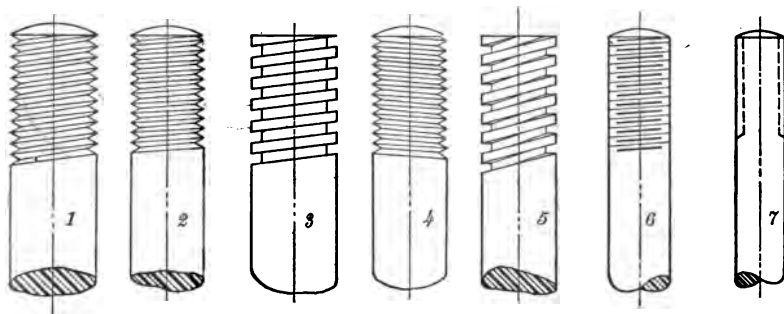

FIG. 103.

spond to the diameter of the thread at the bottom. After some practice these lines can be drawn accurately enough by the eye.

CHAPTER IV.

LETTERING AND FIGURING.

THIS subject has not been given the importance it deserves in connection with mechanical drawing. Many otherwise excellent drawings and designs as far as their general appearance is concerned have been spoiled by poor lettering and figuring.

All lettering on mechanical drawings should be plain and legible, but the letters in a title or the figures on a drawing should never be so large as to make them appear more prominent than the drawing itself.

The best form of letter for practical use is that which gives the neatest appearance with a maximum of legibility and requires the least amount of time and labor in its construction.

This would naturally suggest a "free-hand" letter, but before a letter can be constructed "free-hand" with any degree of efficiency, it will be necessary to spend considerable time in acquiring a knowledge of the form and proportions of the particular letter selected.

It is very desirable then that after the student has carefully constructed as many of the following plates of letters and numbers as time will permit and has acquired a sufficient knowledge of the form and proportions of at least the "Roman" and "Gothic" letters; he should then adopt some one

style and practice that at every opportunity, until he has attained some proficiency in its free-hand construction.

When practicing the making of letters and numbers free-hand, they should be made quite large at first so as to train the hand.

The "Roman" is the most legible letter and has the best appearance, but is also the most difficult to make well, either free-hand or mechanically. However, the methods given for its mechanical construction, Figs. 104 and 105, will materially modify the objections to its adoption for lettering mechanical drawings.

The "Gothic" letter is a favorite with mechanical draftsmen, because it is plain and neat and comparatively easy to construct. (See Fig. 106.)

Among the type specimens given in the following pages the Bold-face Roman Italic on page 70 is one of the best for a good, plain, clear, free-hand letter, and is often used with good success on working drawings. Gillott's No. 303 steel pen is the best to use when making this letter free-hand.

The "Yonkers" is a style of letter that is sometimes used for mechanical drawings. It is easy to construct with either F. Soennecken's Round Writing-pens, single point, or the Automatic Shading-pen. But it lacks legibility, and is therefore not a universal favorite.

A good style for "Notes" on a drawing is the "Gothic Condensed" shown on page 70.

When making notes on a drawing with this letter, the only guides necessary are two parallel lines, drawn lightly in pencil. The letters should be sketched lightly in pencil first,

and then carefully inked, improving spacing and proportions to satisfy the practiced eye.

FIGURING.

Great care should be taken in figuring or dimensioning a mechanical drawing, and especially a working drawing.

To have a drawing accurately, legibly, and neatly figured is considered by practical men to be the most important part of a working drawing.

There should be absolutely no doubt whatever about the character of a number representing a dimension on a drawing.

Many mistakes have been made, incurring loss in time, labor, and money through a wrong reading of a dimension.

Drawings should be so fully dimensioned that there will be no need for the pattern-maker or machinist to measure any part of them. Indeed, means are taken to prevent him from doing so, because of the liability of the workman to make mistakes, so drawings are often made to scales which are difficult to measure with a common rule, such as 2" and 4" = 1 ft.

The following books, among the best of their kind, are recommended to all who desire to pursue further the study of "Lettering": *Plain Lettering*, by Prof. Henry S. Jacoby, Cornell University, Ithaca, N. Y.; *Lettering*, by Charles W. Reinhardt, Chief Draftsman, *Engineering News*, New York; *Free-hand Lettering*, by F. T. Daniels, instructor in C. E. in Tufts College.

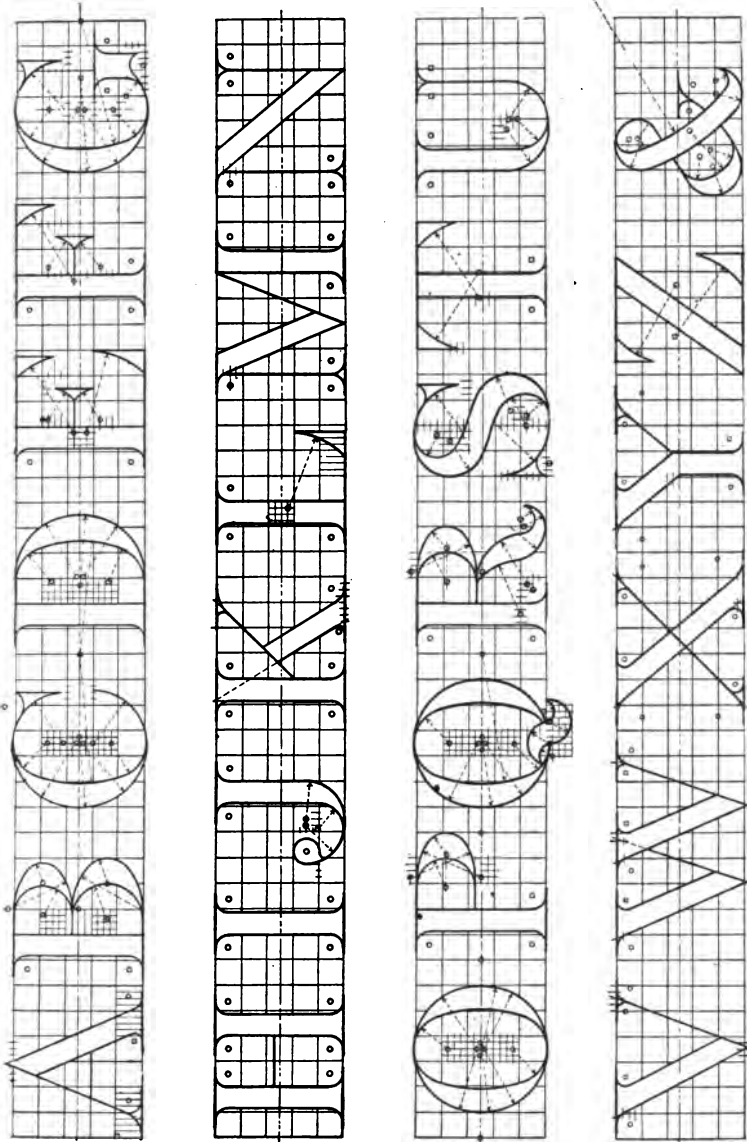

FIG. 104.

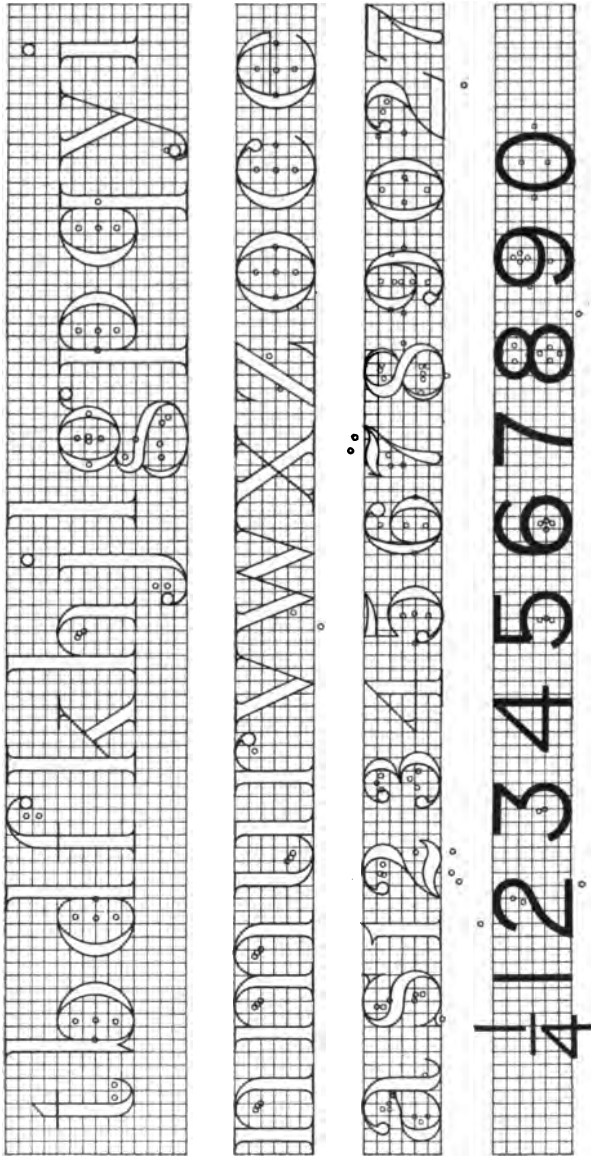

FIG. 105.

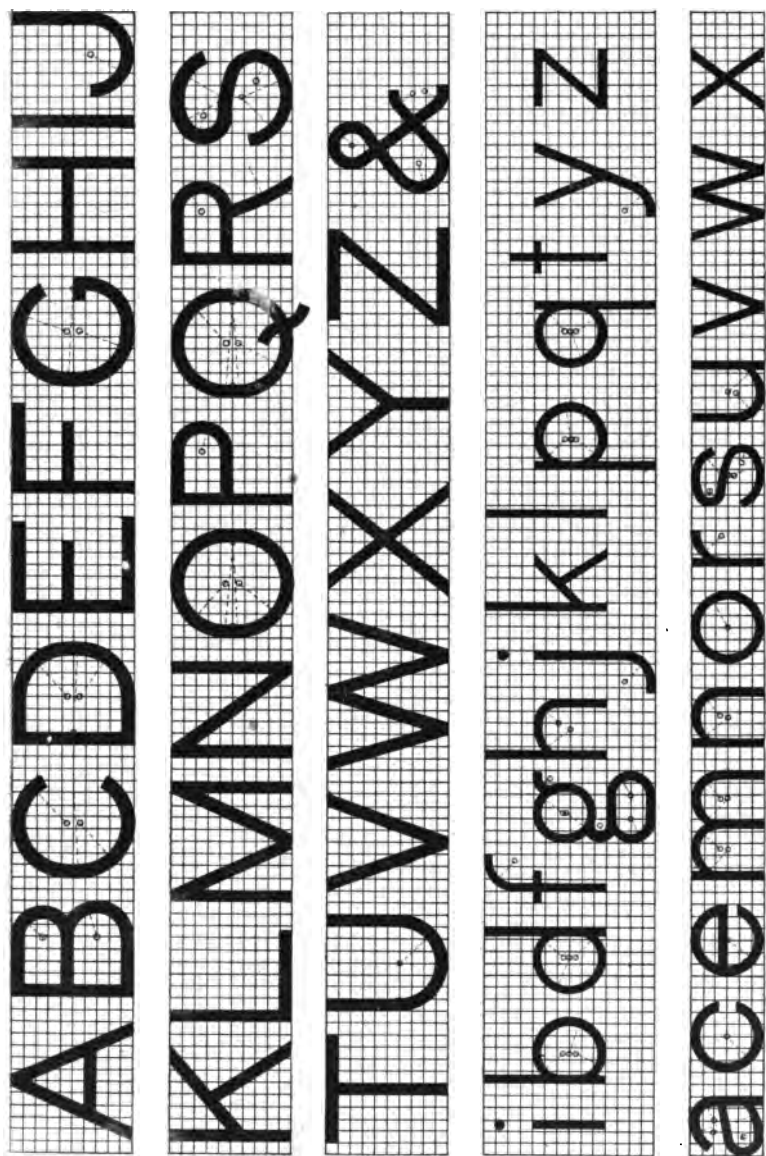

FIG. 106.

18-Point Roman.

ABCDEFGHIJKLMN OPQRSTUVWXYZ
 YZ abcdefghijklmnopqrstuvwxyz
 1234567890

18-Point Italic.

ABCDEFGHIJKLMN OPQRSTUVWXYZ
WXYZ abcdefghijklmnopqrstuvwxyz

12-Point Cushing Italic.

ABCDEFGHIJKLMN OPQRSTUVWXYZ abcdefghijklm
nopqrstuvwxyz 1234567890

28-Point Boldface Italic.

ABCDEFGHIJKLM
NOPQRSTUVWXYZ
abcdefghijklmnopqrstu
vwxyz 1234567890

Two-Line Nonpareil Gothic Condensed.

ABCDEFGHIJKLMN OPQRSTUVWXYZ 1234567890

Three-Line Nonpareil Lightface Celtic.

ABCDEFGHIJKLMN OPQR
 STUVWXYZ abcdefghijkl
 mnopqrstuvwxyz
 1234567890

18-Point Chelsea Circular.

ABCDEFGHIJKLMN OPQRSTUVWXYZ
YZ abcdefghijklmnpqrstuvwxy z
1234567890

18-Point Elandkay.

ABCDEFGHIJKLMN OPQRSTUVWXYZ
1234567890

18-Point Quaint Open.

ABCDEFGHIJKLMN OPQRSTU
WXYZ 1234567890

28-Point Roman.

**ABCDEFGHIJKLM
NOPQRSTUVWXYZ
abcdefghijklmnopqrstu
vwxyz 1234567890**

28-Point Old-Style Italic.

*ABCDEFGHIJKL MNOP
QRSTUVWXYZ abcdefg
hijklmnopqrstuvwxy z
1234567890*

12-Point Victoria Italic.

*ABCDEFGHIJKLMN OPQRSTU
VWXYZ 1234567890*

18-Point DeVenne Italic.

*ABCDEFGHIJKLMN OPQRSTU
VWXYZ abcdefghijklmnopqrst
uvwxyz 1234567890*

22-Point Gothic Italic.

*ABCDEFGHIJKLMN OPQRSTUVWXYZ
abcdefghijklmnopqrstuvwxyz
1234567890*

Double-Pica Program.

*ABCDEFGHIJKLMNO
PQRSTUVWXYZ
abcdefghijklmnopqrstuv
wxyz 1234567890*

Nonpareil Telescopic Gothic.

ABCDEFGHIJKLMN OPQRSTUVWXYZ 1234567890

24-Point Gallican.

A B C D E F G H I J K L
M N O P Q R S T U V W
X Y Z 1 2 3 4 5 6 7 8 9 0

Two-Line Virile Open.

A B C D E F G H I J K L M N O P Q R S T U V W X Y Z
a b c d e f g h i j k l m n o p q r s t u v w x y z
1 2 3 4 5 6 7 8 9 0

22-Point Old-Style Roman.

A B C D E F G H I J K L M N O P Q R S T
U V W X Y Z a b c d e f g h i j k l m n o p q r s t
u v w x y z 1 2 3 4 5 6 7 8 9 0

36-Point Yonkers.

A B C D E F G H I J K L M
N O P Q R S T U V W X
Y Z a b c d e f g h i j k l m n o p q r
s t u v w x y z 1 2 3 4 5 6 7 8 9 0

CHAPTER V.

ORTHOGRAPHIC PROJECTION.

ORTHOGRAPHIC PROJECTION, sometimes called Descriptive Geometry and sometimes simply Projection, is one of the divisions of descriptive geometry; the other divisions are Spherical Projection, Isometric Projection, Shades and Shadows, and Linear Perspective.

In this course we will take up only a sufficient number of the essential principles of Orthographic Projection, Isometric Projection, and Shades and Shade Lines, to enable the student to make a correct mechanical drawing of a machine or other object.

Orthographic Projection is the science and the art of representing objects on different planes at right angles to each other, by projecting lines from the *point of sight* through the principal points of the object perpendicular to the *Planes of Projection*.

There are commonly three planes of projection used, viz., the *H. P.* or *Horizontal Plane*, the *V. P.* or *Vertical Plane*, and the *Pf. P.* or *Profile Plane*.

These planes, as will be seen by Figs. 107 and 109, intersect each other in a line called the *I. L.* or *Intersecting Line*, and form four angles, known as the first, second, third, and

fourth *Dihedral Angles*. Figs. 107 and 109 are perspective views of these angles.

An object may be situated in any one of the dihedral angles, and its projections drawn on the corresponding co-ordinate planes.

Problems in Descriptive Geometry are usually worked out in the first angle, and nearly all English draftsmen project their drawings in that angle, but in the United States the third angle is used almost exclusively. There is good reason for doing so, as will be shown hereafter.

We will consider first a few projection problems in the first angle, after which the third angle will be used throughout.

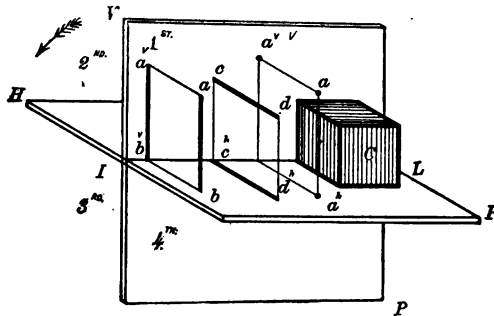

FIG. 107.

H.P., Fig. 107, is the Horizontal Plane, V.P. the Vertical Plane, and I.L. the Intersecting Line.

The Horizontal Projection of a point is where a perpendicular line drawn through the point pierces the H.P.

The Vertical Projection of a point is where a per. line drawn through the point pierces the V.P.

Conceive the point *a*, Fig. 107, to be situated in space 4'' above the H.P. and 3'' in front of the V.P. If a line is passed through the point *a* per. to H.P. and produced until

it pierces the H.P. in the point a^h , a^v will be the Hor. Proj. of the point a .

If another line is projected through the point a per. to the V.P. until it pierces the V.P. in the point a^v , a^v is the vertical projection of the point a .

If now the V.P. is revolved upon its axis I.L. in the direction of the arrow until it coincides with the H.P. and let the H.P. be conceived to coincide with the plane of the drawing-paper, the projections of the point a will appear as shown by Fig. 108.

The vertical projection a^v 4'' above the I.L. and the horizontal projection a^h 3'' below the I.L. both in the same straight line.

In mechanical drawing the vertical projection a^v is called the *Elevation* and the horizontal projection a^h the *Plan*.

The projections of a line are found in a similar manner, by first finding the projections of the two ends of the line, and joining them with a straight line.

Let ab be a line in space $3\frac{1}{2}$ '' long, parallel to the V.P. and perpendicular to the H.P. One end is resting on the H.P. $2\frac{1}{2}$ '' from the V.P.

The points a and b will be vertically projected in the points a^v and b^v . Join $a^v b^v$. $a^v b^v$ is the vertical projection of the line ab .

When a line is perpendicular to one of the planes of projection, its projection on that plane is a point, and the projection on the other plane is a line equal to the line itself.

ab , Fig. 107, is perpendicular to the H.P., therefore its proj. on the H.P. when viewed in the direction ab will be seen to be a point.

Conceive now the V.P. revolved as before, the V. proj. will be found to be at $a^v b^v$, Fig. 108, and the H. proj. at the point a^h .

cd , Fig. 107, is a line parallel to the H.P. and perpendicular to the V.P. Its elevation or V. proj. is the point d^v , Fig. 108, and its plan or H. proj. the line $c^h d^h$ perpendicular to the Intersecting Line and equal in size to the line itself.

Planes or Plane Surfaces bounded by lines are projected by the same principles used to project lines and points.

Let $aa^v b^v b$, Fig. 107, be a plane at right angles to and touching both planes of projection.

The elevation of the front upper corner a is projected in the point a^v . The elevation of the front lower corner b is projected in the point b^v . Join $a^v b^v$. $a^v b^v$ is the vertical projection of the front edge ab of the plane. The plan of the front

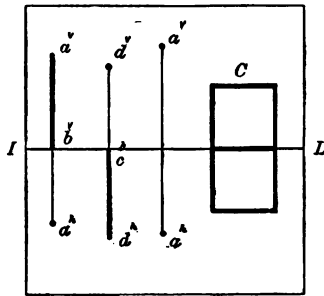
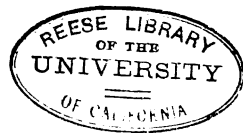

FIG. 108.

upper corner is projected in the point b and the point a^v in the point b^v . A straight line joining bb^v is the plan or horizontal projection of the top edge of the plane.

On the drawing-paper the plan and elevation of the plane $aa^v b a$ would be shown as a continuous straight line a^v to a^h Fig. 108.



Solids bounded by plane surfaces are projected by means of the same principles used to project planes, lines, and points.

C, Fig. 107, is a cube bounded by six equal sides or surfaces. The top and bottom being parallel to the H.P. and the front and back parallel to the V.P., the vert. proj. is a square above I.L. equal in area to any one of the six faces of the cube. The hor. proj. is a similar square below I.L.

These projections are shown at *C*, Fig. 108, as they would appear on the drawing-paper.

The foregoing illustrates a few of the simple principles of projection in relation to points, lines, and solids when placed in the first dihedral angle, and we find that the plan is always *below* and the elevation always *above* the I.L.

Let us now consider the same problems when situated in the *third angle*. The point *a*, Fig. 109, is behind of the V.P.

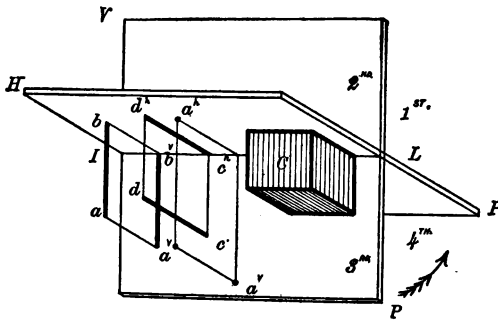

FIG. 109.

and below the H.P. Draw through *a* perpendiculars to the plane of projection. The Hor. proj. is found at a^h and the vert. proj. at a^v .

Conceive again the V.P. to be revolved in the direction of the arrow until it coincides with the H. P. The hor. proj.

will then appear at a^h above the I.L. and the vert. proj. at a^v below the I.L., Fig. 110. And so with the lines, the planes, and the solids.

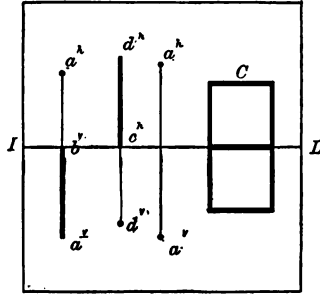

FIG. 110.

In order to still further explain the use of the planes of projection, with regard to objects placed in the third angle, let us suppose a truncated pyramid surrounded by imaginary planes at right angles to each other, as shown by Fig. 111.

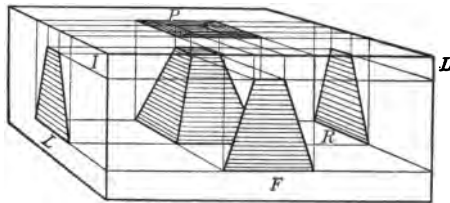

FIG. 111.

With a little attention it will easily be discerned that the pyramid is situated in the third dihedral angle, and that in addition to the V. and H. planes, we have passed two profile planes at right angles to the V. and H. planes, one at the right-hand and one at the left.

When the pyramid is viewed orthographically through each of the surrounding planes, four separate views are had,

exactly as shown by the projections on the opposite planes, viz., a Front View, Elevation, or Vert. Proj. at F.; a Right-hand View, Right-end Elevation, or Right-profile Projection at R.; a Left-hand View, Left-end Elevation, or Left-profile Projection at L.; a Top View, Plan or H. Proj. at P.

If we now consider the V.P. and the right and left profile planes to be revolved toward the beholder until they coincide, using the front intersecting lines as axes, the projections of the pyramid will be seen as shown by Fig. 112, which when the

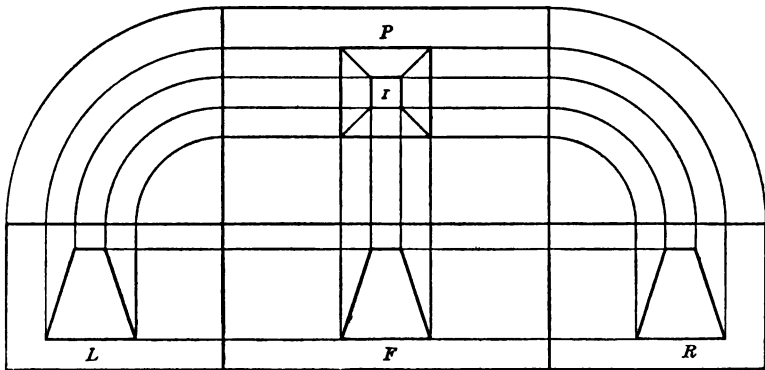

FIG. 112.

imaginary planes and projecting lines have been removed, will be a True Drawing or Orthographic Projection of the truncated pyramid.

NOTATION.

In the drawings illustrating the following problems and their solutions the *given* and *required* lines are shown *wide* and *black*. *Hidden* lines are shown *broken* into short dashes a little narrower than the *visible* lines. *Construction* or *projection* lines are drawn with very narrow *full* or *continuous* black lines.

When convenient very narrow, continuous *blue* lines are sometimes used.

The Horizontal Plane is known as the H.P., the Vertical Plane as V.P. and the Profile Plane as Pf.P.

A point in space is designated by a small letter or figure, their projection by the same letters or figures with small *h* or *v* written above for the horizontal or vertical projection respectively.

In some complicated problems where points are designated by figures their projections are named by the same figures accented.

Drawings should be carefully made to the dimensions given, the scale to be determined by the instructor.

The student should continually endeavor to improve in inking straight lines, curves, and joints.

In solving the following problems the student should have a model of the co-ordinate planes for his own use. This can be made by taking two pieces of stiff cardboard and cutting a slot in the center of one of them large enough to pass the folded half of the other through it; when unfolding this half a model will be had like that shown by Fig. 107 or 109.

All projections shall now be made from the third, dihedral angle.

PROB. 1.—A point a is situated in the third dihedral angle, 1" below the H.P. and 3" behind the V.P.

It is required to draw its vertical and horizontal projections.

Draw a straight line $a^h a^v$, Fig. 113, perpendicular to I.L. and measure off the point a^v 1" below I.L. and the point a^h 3" above I.L.

a^v is the vertical and a^h the horizontal projection in the same straight line $a^v a^h$.

The student should demonstrate this with his model.

PROB. 2.—Draw two projections of a line 3'' long parallel to both planes, $\frac{3}{4}$ '' below the H.P. and 2'' behind the V.P.

As the line is parallel to both planes, both projections will be parallel to the I.L.

Draw $a^v b^v$ the vert. proj. of the line 3'' long, Fig. 114, parallel to I.L. and $\frac{3}{4}$ '' below it. Draw the hor. proj. 2'' above the I.L. and parallel to it, making it the same length as the

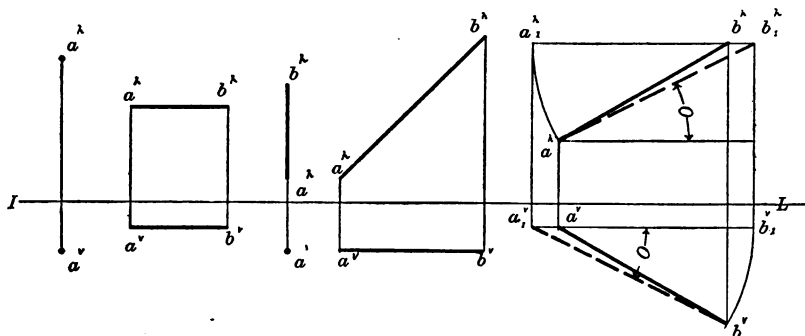

FIG. 113. FIG. 114. FIG. 115. FIG. 116.

FIG. 117.

vert. proj. by drawing lines perpendicular to I.L. from the points a^v and b^v to a^h and b^h .

PROB. 3.—To draw the hor. and vert. proj. of a straight line 3'' long, per. to the vert. plane, Fig. 115.

As the line is per. to the vert. plane the vert. proj. will be a point below the I.L. and the hor. proj. will be parallel to the horizontal plane and per. to I.L.

PROB. 4.—To draw the plan and elevation of a straight line 6'' long making an angle of 45° with the vert. plane and par. to the hor. plane, Fig. 11

The plan or hor. proj. will be above the I.L. and make an angle of 45° with it. The elevation or vert. proj. will be below and par. to I.L.

Draw from the point a^h at any convenient distance from I.L. a straight line $a^h b^h$ 6'' long, making an angle 45° with I.L.

Draw $a^v b^v$ par. to I.L. at a convenient distance below it. The length of the elevation or vert. proj. is determined by dropping perpendiculars from the end of the hor. proj. $a^h b^h$ to the points $a^v b^v$.

PROB. 5, FIG. 117.—To find the true length of a straight line oblique to both planes of projection and the angle it makes with these planes.

$a^v b^v$ and $a^h b^h$ are the projections of a straight line oblique to V.P. and H.P. Using a^v as a pivot, revolve the line $a^v b^v$ until it becomes parallel to I.L. as shown by $a^v b_1^v$. From the point b_1^v erect a per. Through the point b^h draw a line par. to I.L. cutting the per. in the point b_1^h .

The broken line $a^h b_1^h$ is the true length of the line ab , and the angle θ is the true angle which the line makes with V.P.

To find the angle it makes with H.P. :

Using b^h as a pivot, revolve the line $b^h a^h$ until it becomes par. to I.L. as shown by $b^h a_1^h$. From the point a_1^h drop a per. Through the point a^v draw a line par. to I.L. intersecting the per. at the point a_1^v θ is the angle which the line ab makes with H.P. and the broken line $a_1^v b^v$ is again its true length.

PROB. 6, FIG. 118.—To project a plane surface of given size, situated in the third angle and par. to the V.P.

Let $abcd$ be the plane surface 3'' long \times 2'' wide. If we conceive lines to be projected from the four corners of the

plane surface to the V.P. and join them with straight lines we will have its V. projection $a^v b^v c^v d^v$ and shown by Fig. 118. And as the plane surface is par. to the V.P. it must be per to the H.P. since the planes of projection are at right angles to each other. So the plan or H. projection will be a straight line equal in length to one of the sides of the plane surface.

At a convenient distance above I.L. draw a straight line, and from the points $a^v b^v$ project lines at right angles to I.L., cutting the straight line in the points $a^h b^h$. The line $a^h b^h$ is the hor. proj. of the plane surface $abcd$.

PROB. 7, FIG. 118.—To draw the projections of a plane surface of given dimensions when situated in the third angle perpendicular to the H.P. and making an angle with the V.P.

Let the plane surface be $3'' \times 2''$ as before and let the angle it makes with V.P. be 60° .

To draw the plan;

At a convenient distance above I.L. and making an angle of 60° with it, draw $a^h b_1^h$, Fig. 118, $2''$ long. From b_1^h drop a per. cutting $a^v b^v$ in the point b_1^v and $c^v d^v$ in the point d_1^v , then the rectangle $a^v b_1^v d_1^v c^v$ will be the vert. proj. or elevation of the plane surface $abcd$.

PROB. 8, FIG. 119.—To draw the projections of the same plane surface (1) when parallel to the H.P., (2) when making an angle of 30° with H.P. and per. to V.P., (3) when making an angle of 60° with H.P. and per. to V.P., and (4) when per. to both planes.

Fig. 119 shows the projections; further explanations are unnecessary.

PROB. 9, FIGS. 119 AND 120.—To draw the projections of

the same plane surface when making compound angles with the planes of projection.

Let the plane make an angle of 30° with H.P., as in the second position of Prob. 8, Fig. 119, and in addition to that, revolve it through an angle of 30° . First, draw the plane parallel to H.P., as shown by $a^h c^h b^h d^h$, Fig. 119, the true size of the plane.

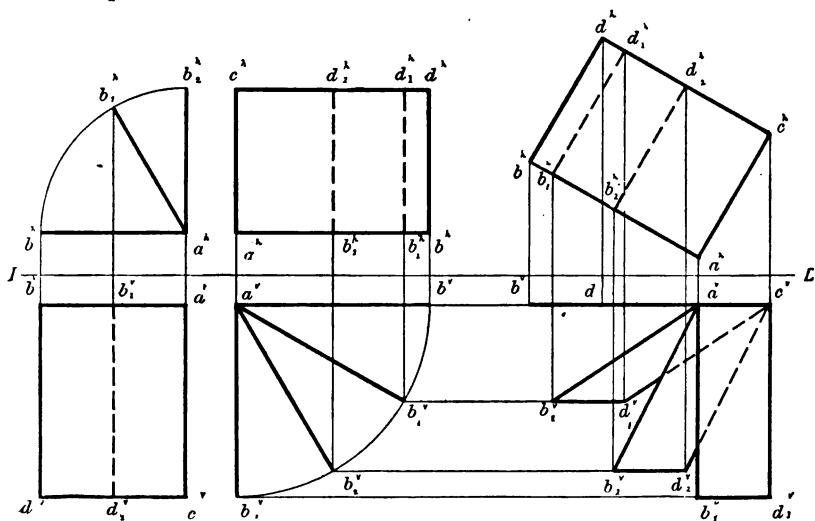

FIG. 118.

FIG. 119.

FIG. 120.

Its elevation will be the straight line $a^v b^v$ parallel to I.L. Next revolve $a^v b^v$, using a^v as a pivot, through an angle of 30° , to the position $a^v b_1^v$, which is its vert. proj. when making an angle of 30° with H.P. Its plan is projected in $a^h b_1^h c^h d_1^h$.

Now as the plane is still to make an angle of 30° with H.P. after it has been revolved through an angle of 30° with relation to the V.P., its hor. proj. will remain unchanged.

With a piece of celluloid or tracing-paper trace the hor. proj. $a^h b_1^h c^h d_1^h$, lettering the points as shown, and revolve the

tracing through the angle of 30° , or, which is the same thing, place the tracing so that the line $a^h c^h$ will make an angle of 60° with I.L., and with a sharp conical-pointed pencil transfer the four points to the drawing-paper and join them by straight lines, as shown by Fig. 120.

And as the line $a^h c^h$ retains its position relative to H.P. after the revolution, its elevation will be found at $a^v c^v$, Fig. 120, in a straight line drawn through $a^v b^v$, Fig. 119, intersecting perpendiculars from $a^h c^h$, Fig. 120. And the vert. proj. of the points $b_1^h d_1^h$ will be found at $b_1^v d_1^v$, Fig. 120, in a straight line drawn through b_1^v , Fig. 119, parallel to I.L. and intersecting pers. from $b_1^h d_1^h$, join with straight lines the points $a^v b_1^v c^v d_1^v$.

Draw the projections of the plane when making an angle of 60° with H.P. and revolved through an angle of 30° with relation to V.P.

Draw the projections of the plane when making an angle of 60° with the V.P. and per. to the H.P., Fig. 120.

PROB. 10.—To draw the projections of a plane surface of hexagonal form in the following positions: (1) When one of its diagonals is par. to the V.P. and making an angle of 45° with the H.P. (2) When still making an angle of 45° with the H.P. the same diagonal has been revolved through an angle of 60° .

Draw the hexagon $1^h 2^h 3^h 4^h 5^h 6^h$, Fig. 121, at any convenient distance above I.L., making the inscribed circle $= 2\frac{1}{2}''$. This will be its hor. proj. and $2^v 4^v 6^v 1^v$ its vert. proj., the diagonal $1^h 4^h$ being par. to both planes of proj. With 1^v as an axis revolve $6^v 4^v 2^v$ through an angle of 45° . Through the points $2_1^v 4_1^v 6_1^v$ erect pers. to the points $6_1^h 5_1^h 4_1^h 3_1^h$ and 2_1^h

and join them with straight lines. These are the projs. in the first position. Now trace the hor. proj, $1^h, 2^h,$ etc., on a piece of celluloid or tracing-paper and revolve the tracing until the diagonal $1^h 2^h$ makes an angle of 60° with the I.L., Fig. 122. Next draw pers. from the 6 points of the hexagonal plane to intersect hors. from the corresponding points of the elevation in Fig. 121, join the points of intersection with

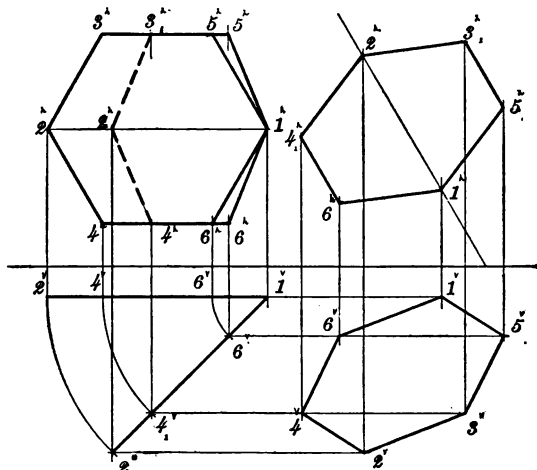

FIG. 121.

FIG. 122.

straight lines, and so complete the projections of the second position, Fig. 122.

PROB. 11, FIGS. 123 AND 124.—Draw the projs. of a circular plane (1) when its surface is par. to the vert. plane, (2) when it makes an angle of 45° with the V.P., and (3) when still making an angle of 45° with the V.P. it has been revolved through an angle of 60° .

First position: Draw the circular plane $1^v, 2^v, 3^v, 4^v,$ etc., Fig. 123, below the I.L. with a radius = r and divide and figure it as shown.

Since the plane is par. to V.P. its hor. proj. will be a straight line $1^h, 2^h, \dots$ etc.

For the second position revolve the said hor. proj. through the required angle of 45° to the position $a^h \dots 1_1^h$, Fig. 123, and through each division in $1^h \dots a^h$ draw arcs cutting $a^h \dots 1_1^h$ in points $2^h 3^h \dots$. This is the hor. proj. of the plane when making an angle of 45° with the V.P.

The elevation is found by dropping pers. from the points in the hor. proj. $a^h \dots 1_1^h$ to intersect hor. lines drawn through the correspondingly numbered points in the eleva-

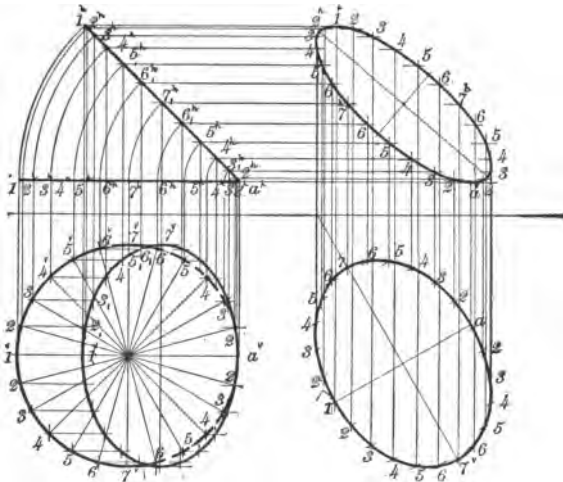

FIG. 123.

FIG. 124.

tion and through these intersections draw the elevation or vert. proj. of the second position.

For the third position make a tracing of the elevation of the second position, numbering all the points as before, and place the tracing so that the diameter $7^v 7^v$ makes the required angle of 60° with the I.L. and transfer to the drawing-paper.

The result will be the elevation of the third position shown below the I.L., Fig. 124. Its hor. proj. is found by drawing pers. through the points 1, 2, 3, 4 . . . to intersect hors. drawn through the corresponding points in the hor. proj. of the 2d position and through these intersections draw the plan or hor. proj. of the third position, Fig. 124.

PROB. 12, FIG. 125.—Draw the projs. of a regular hexagonal prism, 3'' high and having an inscribed circle of $4\frac{5}{8}$ '' diam.: (1) When its axis is par. to the V.P. (2) Draw the true form of a section of the prism when cut by a plane passing through it at an angle of 30° with its base. (3) Draw the projection of a section when cut by a plane passing through *XX*, Fig. 125, per. to both planes of proj.

The drawing of the I.L. may now be omitted.

For the plan of the first part of this prob. draw a circle with a radius = to $2\frac{5}{8}$ '', and circumscribe a hexagon about it, as shown by $a^h, b^h, c^h, d^h, e^h, f^h$, etc., Fig. 125. To project the elevation, draw at a convenient distance from the plan a hor. line par. to $a^h d^h$, and 3'' below it another line par. to it. From the points $a^h b^h c^h d^h e^h f^h$, drop pers. cutting these par. lines in the points $a^v b^v c^v d^v e^v f^v$, thus completing the elevation of the prism.

Second condition: Draw the edge view or trace of the cutting plane $1'4'$, making an angle of 30° with the base of the prism, locating the lower end $4'$ one-half inch above the base; parallel to $1'4'$, and at a convenient distance from it draw a straight line 1, 4; at a distance of $2\frac{5}{8}$ '' on each side of 1, 4 draw lines 3, 2 and 5, 6 parallel to 1, 4, and through the points $1'2'3'4'$ let fall pers. cutting these three par. lines in the points 1, 2, 3, 4, 5, 6; join these points by straight lines

as shown, and a true drawing of the section of the prism as required will result.

For the third condition of the problem :

Let XX be the edge view of the cutting plane and conceive that part of the prism to the right of XX to be removed.

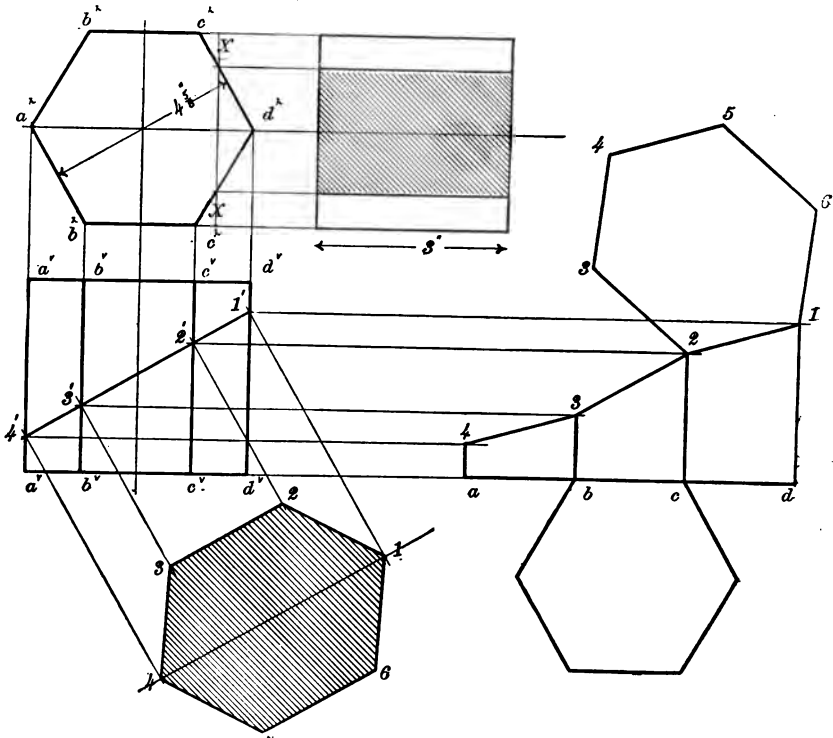

FIG. 125.

FIG. 126.

From the hor. proj. of the prism draw a right-hand elevation or profile proj., and through the points XX draw the lines enclosing the section, and hatch-line it as shown.

PROB. 13.—To draw the development of the lower part of the prism in the elevation of the last problem.

To the right of the elevation in Fig. 125, prolong the base line indefinitely and lay off upon it the distances ab , bc , cd , etc., Fig. 126, each equal in length to a side of the hex. At these points erect pers., and through the points $1'2'3'4'$ draw hor. lines intersecting the pers. in 4, 3, 2, 1, etc. At bc draw the hex. $a^h b^h c^h d^h$ of the last prob. for the base, and at 1, 2 draw the section 1, 2, 3, 4, 5, 6 for the top.

PROB. 14, FIG. 127.—To draw the projs. of a right cylinder 3'' diam. and 3'' long. (1) When its axis is per. to the H.P. (2) Draw the true form of a section of the cylinder, when cut by a plane per. to the V.P. making an angle of 30° with the H.P. (3) Draw a development of the upper part of the cyl.

For the plan of the first condition, describe the circle $1'$, $2'$, etc., with a radius = $1\frac{1}{2}''$ and from it project the elevation, which will be a square of 3'' sides.

For the second condition: Let 1, 7 be the trace of the cutting plane, making the point 7, $\frac{1}{2}''$ from the top of the cyl. Divide the circle into 12 equal parts and let fall pers. through these divisions to the line of section, cutting it in the points 1, 2, 3, 4, etc. Parallel to the line of section 1, 7 draw $1''7''$ at a convenient distance from it, and through the points 1, 2, 3, 4, etc., draw pers. to 1, 7, intersecting and extending beyond $1''7''$. Lay off on these pers. the distances $6''8'' = 6'8'$, and $5''9'' = 5'9'$, etc., and through the points $2''$, $3''$, $4''$, etc., describe the ellipse.

For the development: In line with the top of the elevation draw the line $g'g''$ equal in length to the circumference of the circle, and divide it into 12 equal parts a' , b' , etc., a' , b'' , etc. Through these points drop pers. and through the points

1, 2, 3, etc., draw hors. intersecting the pers. in the points 1, 2, 3, etc., and through these points draw a curve.

Tangent to any point on the straight line draw a 3'' circle for the top of the cyl. and tangent to any suitable point on the curve transfer a tracing of the ellipse.

PROB. 15, FIG. 128.—Draw the projections of a right cone 7'' high, with a base 6'' in diam., pierced by a right cyl. 2'' in

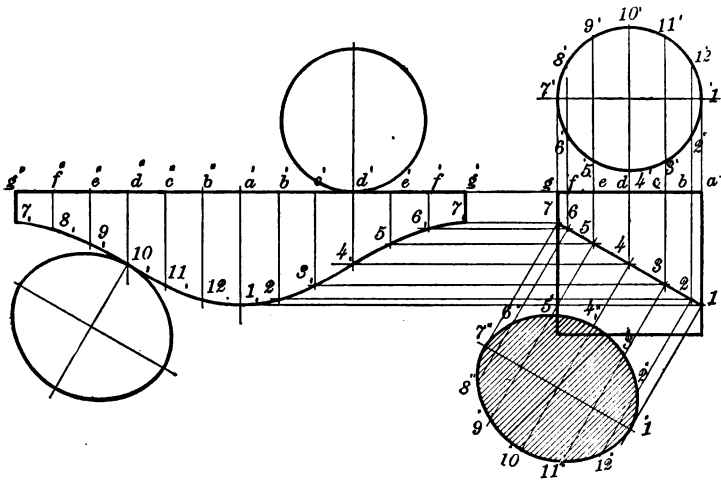

FIG. 127.

diam. and 5'' long their axes intersecting at right angles 3'' above the base of the cone and par. to V.P. Draw first the plan of the cone with a radius = $3\frac{1}{2}$ ''.

At a convenient distance below the plan draw the elevation to the dimensions required.

3'' above the base of the cone draw the center line of the cyl. *CD*, and about it construct the elevation of the cyl., which will appear as a rectangle 2'' wide and $2\frac{1}{2}$ '' each side of the axis of the cone. The half only appears in the figure.

To project the curves of intersection between the cyl. and cone in the plan and elevation: Draw to the right of the cyl. on the same center line a semicircle with a radius equal that of the cyl. Divide the semicircle into any number of parts,

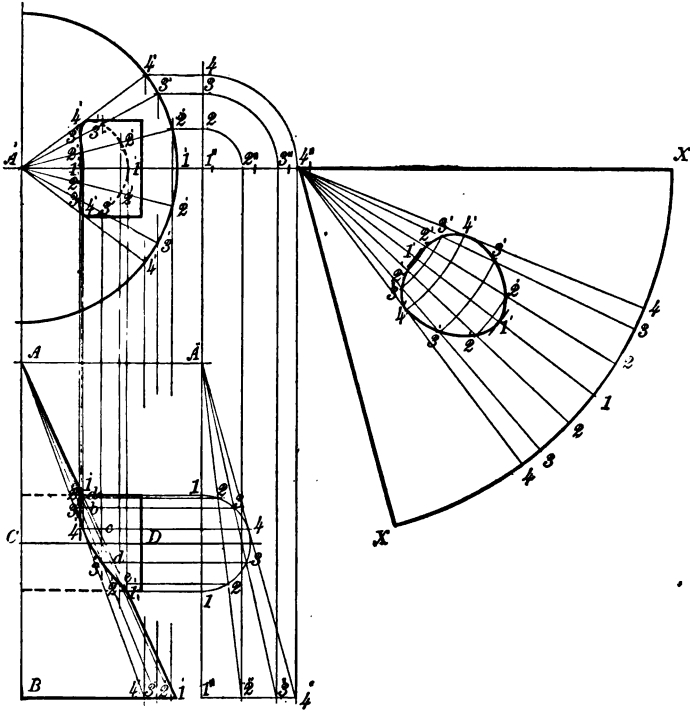

FIG. 128.

FIG. 129.

as 1, 2, 3, 4, etc. Through 1, 1 draw the per. $A'' 1''$ equal in length to the height of the cone, and through A'' draw the line $A'' 4''$ tangent to the semicircle at the point 4, and through the other divisions of the semicircle draw lines from A'' to the line $1'' 4''$, meeting it in the points $3'' 2''$.

From all points on the line $1'' 4''$, viz., $1'' 2'' 3'' 4''$, erect

pers. to the center line of the plan, cutting it in the points $1_1''2_1''3_1''4_1''$, and with $1_1''$ as the center draw the arcs $2_1''-2$, $3_1''-3$, $4_1''-4$ above the center line of the plan, and through the points $2, 3, 4$ draw hors. to intersect the circle of the plan in the points $2'3'4'$, and lay off the same distances on the other side of the center line of the plan in same order, viz., $2'3'4'$. Through each of these points on the circumference of the circle of the plan draw radii to its center A' , and through the same points also in the plan let fall pers. to the base of the elevation of the cone, cutting it in the points $2'3'4'$; and from the apex A of the elevation of the cone draw lines to the points $2'3'4'$ on the base: Hor. lines drawn through the points of division $2, 3, 4$ on the semicircle will intersect the elements $A-2', A-3', A-4'$ of the cone in the points $2'3'4'$; these will be points in the elevation of the curve of intersection between the cylinder and the cone.

The plan of the curve is found by erecting pers. through the points in the elevation of the curve to intersect the radial lines of the plan in correspondingly figured points, through which trace the curve as shown. Repeat for the other half of the curve.

PROB. 16, FIG. 129.—To draw the development of the half cone, showing the hole penetrated by the cyl.

With center $4_1''$, Fig. 129, and element $A1'$ of the cone, Fig. 128, as radius, describe an arc equal in length to the semicircle of the base of the cone. Bisect it in the line $4_1''1$, and on each side of the point 1 lay off the distances $2, 3, 4$, equal to the divisions of the arc in the plan Fig. 128, and from these points draw lines to $4_1''$, the center of the arc. Then with radii $A-a, b, c, d, e$, respectively, on the elevation Fig. 128,

and center $4_1''$ draw arcs intersecting the lines drawn from the arc XX to its center $4_1''$. Through the points of intersection draw the curve as shown by Fig. 129.

PROB. 17, FIG. 130.—To draw the development of the half of a truncated cone, given the plan and elevation of the cone.

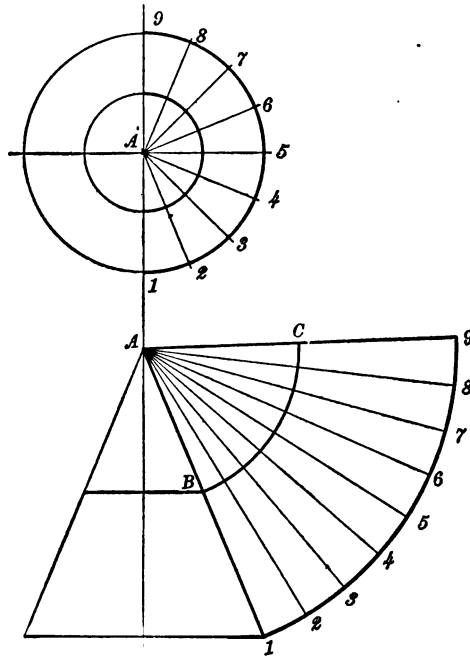

FIG. 130.

Divide the semicircle of the plan into any number of parts, then with A as center and $A1$ as radius, draw an arc and lay off upon it from the point 1 the divisions of the semicircle from 1 to 9, draw $9A$. Then with center A and radius AB draw the arc BC . $1BC9$ is the development of the half of the cone approximately.

PROB. 18, FIG. 131.—To draw the curve of intersection of a small cyl. with a larger. To the left of the center-line of Fig. 131 is a half cross-section, and to the right a half elevation of the two cyls.

Draw the half plan of the small cyl., which will be a semicircle, and divide it into any convenient number of parts, say 12.

From each of these divisions drop pers.

On the half cross-section these pers. intersect the circumference of the large cyl. in the points 1', 2', etc. Through

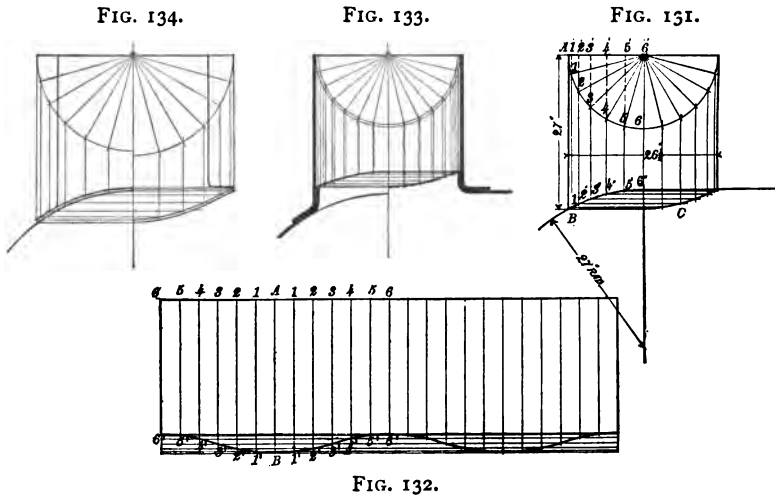

these points draw hors. to intersect in corresponding points the pers. on the half elevation. Through the latter points draw the curve of intersection *C*.

PROB. 19.—To draw the development of the smaller cyl. of the last prob.

Draw a rectangle, Fig. 132, with sides equal to the circum-

ference and length of the cyl. respectively, and divide it into 24 equal parts.

Make AB , $1'1'$, $3'3'$, etc., Fig. 132, equal to AB , $1'1''$, $2'2''$, $3'3''$, etc., Fig. 131, and draw the developed curve of intersection.

PROB. 20.—To draw the orthographic projections of a cylindrical dome riveted to a cylindrical boiler of given dimensions.

Let the dimensions of the dome and boiler be: dome $26\frac{1}{2}''$ diam. \times $27''$ high, boiler $54''$ diam., plates $\frac{1}{2}''$ thick.

Apply to the solution of this problem the principles explained in Prob. No. 18, Fig. 131.

When your drawings are completed, compare them with Figs. 133 and 134, which are the projections required in the problem.

Letter or number the drawing and be prepared to explain how the different projections were found.

PROB. 21.—To draw the development of the top gusset-sheets of a locomotive wagon-top boiler of given dimensions.

First draw the longitudinal cross-section of the boiler to the dimensions given by Fig. 135, using the scale of $1'' = 1$ ft.

Then at any convenient point on your paper draw a straight line, and upon it lay off a distance AB $35\frac{1}{2}''$ long = the straight part of the top of the gusset-sheet G , Fig. 135. With center A and a radius = $27\frac{7}{8}''$ (the largest radius of the gusset) $+ 6''$ (the distance from the center of the boiler to the center of the gusset C , Fig. 135) = $33\frac{7}{8}''$, draw arc 1.

With center B and a radius = $26\frac{1}{8}''$ (the smallest radius of the gusset) draw arc 2. Tangent to these arcs draw the

straight line 1, 2 extended, and through the points *A* and *B* draw lines 1, *A* and 2, *B* per. to 1, 2.

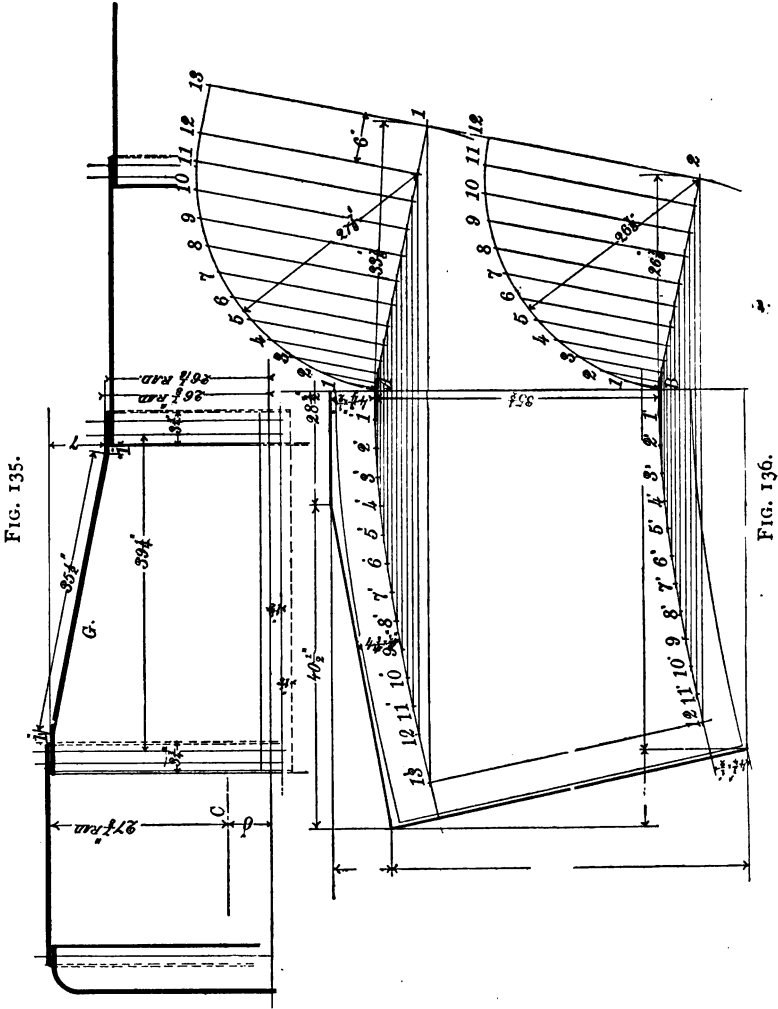

Take a point on the per. 1, 2, 6'' from the point *I* as a center and through the point *A* draw an arc with a radius = $27\frac{7}{8}$ ''.

With point 2 as a center and $2B$ as a radius ($26\frac{1}{8}''$) draw an arc through B to meet the line 1, 2.

Divide both arcs into any number of parts, say 12, and through these divisions draw lines per. to and intersecting $1A$ and $2B$ respectively. Through these intersections draw indefinite hors. and on these hors. step off the length of the arcs, with a distance = one of the 12 divisions as follows:

On the first hors. lay off the length of the arc $A1'$ and $B1'$ = $A1$ and $B1$ respectively. Then from $1'$ lay off the same distance to $2'$ on the second hors. etc. Through these points draw curves $A13'$ and $B12'$. Join points $12'$ and $13'$ with a straight line. Then $AB12, 13$ will be the developed half of the straight part of the gusset.

On the two ends or front and back of the gusset we have now to add $1''$ for clearance + $3\frac{3}{4}''$ for lap + $\frac{1}{2}''$ allowance for truing up the plates, total = $5\frac{1}{4}''$. And to the sides $2\frac{5}{8}''$ for lap + $\frac{1}{2}''$ allowance for truing up, total = $3\frac{1}{8}''$.

The outline of the developed sheet may now be drawn to include these dimensions with as little waste as possible, as shown by Fig. 136. Extreme accuracy is necessary in making this drawing, as the final dimensions must be found by measurement.

PROB. 22.—To draw the projections of a V-threaded screw and its nut of $3''$ diam. and $\frac{1}{2}''$ pitch.

Begin by drawing the center line C , Fig. 137, and lay off on each side of it the radius of the screw $1\frac{1}{2}''$. Draw AB and $6D$. Draw $A6$ the bottom of the screw, and on AB step off the pitch = $\frac{1}{2}''$, beginning at the point A .

On line $6D$ from the point 6 lay off a distance = half the pitch = $\frac{3}{8}''$, because when the point of the thread has com-

pleted half a revolution it will have risen perpendicularly a distance = half the pitch, viz., $\frac{1}{2}''$.

Then from the point $6''$ on $6D$ step off as many pitches as may be desired. From the points of the threads just found,

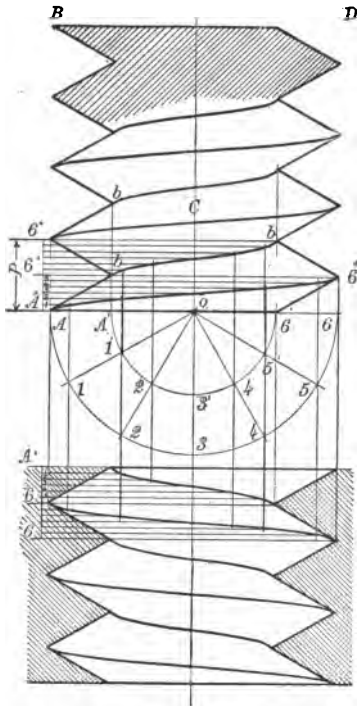

FIG. 137.

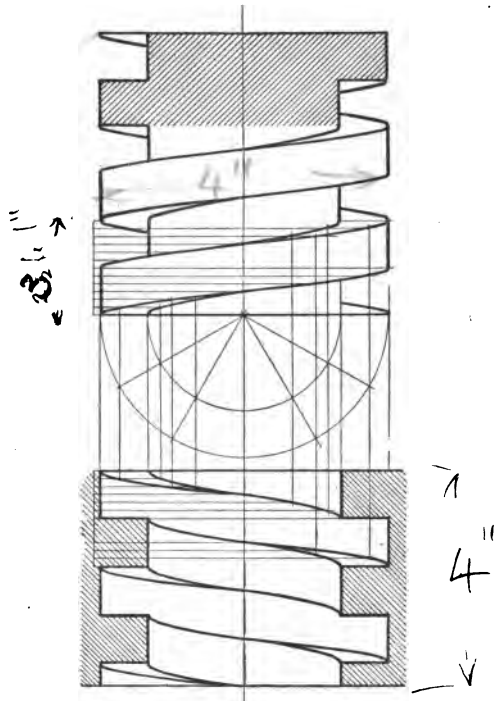

FIG. 138.

draw with the 30° triangle and T-square the V of the threads intersecting at the points $b . . b . .$ the bottom of the threads.

At the point O on line $A6$ draw two semicircles with radii \parallel the top and bottom of the thread respectively. Divide these into any number of equal parts and also the pitch P into the same number of equal parts. Through these divisions draw hors. and pers. intersecting each other in the points as

shown by Fig. 137, which shows an elevation partly in section and a section of a nut to fit the screw. Through the points of intersection draw the curves of the helices shown, using No. 3 of the "Sibley College Set" of Irregular Curves.

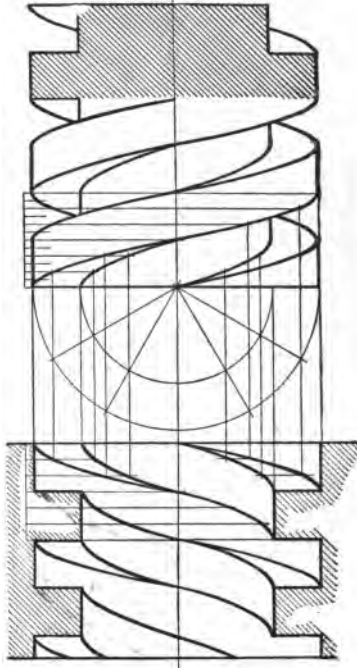

FIG. 139.

PROB. 22.—To draw the proj. of a square-threaded screw 3" diam. and 1" pitch and also a section of its nut.

The method of construction is the same as for the last problem, and is illustrated by Fig. 138.

PROB. 22.—To draw the projections of a square double threaded screw of 3" diam. and 2" pitch, and also a section of its nut.

The solution of this problem is shown by Fig. 139, and further explanation should be unnecessary.

PROB. 23.—To draw the curve of intersection that is formed by a plane cutting an irregular surface of revolution.

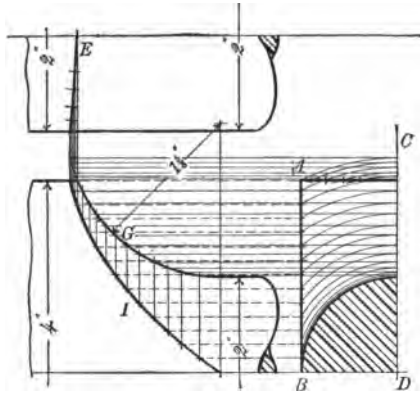

FIG. 140.

Figs. 140, 141, and 142 show examples of engine connecting rod ends where the curve *I* is formed by the inter-

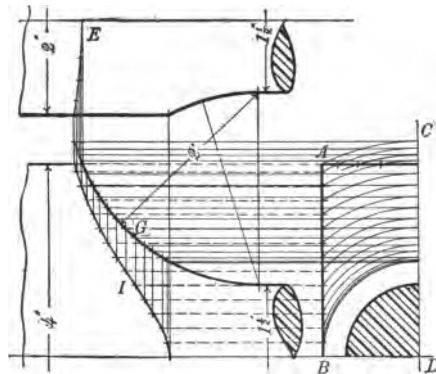

FIG. 141.

section of the flat stub end with the surface of revolution of the turned part of the rod.

The method of finding the curves of intersection are so plainly shown by the figures that a detailed explanation is deemed unnecessary.

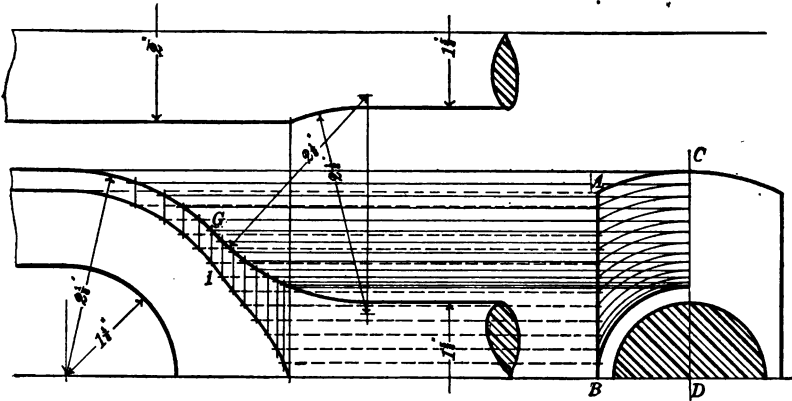

FIG. 142.

SHADE LINES AND SHADING.

Shade Lines are quite generally used on engineering working drawings; they give a relieving appearance to the projecting parts, improve the looks of the drawing and make it easier to read, and are quickly and easily applied.

The *Shading* of the curved surfaces of machine parts is sometimes practiced on specially finished drawings, but on working drawings most employers will not allow shading because it takes too much time, and is not essential to a quick and correct reading of a drawing, especially if a system of shade lines is used.

Some of the principles of shade lines and shading are given below, with a few problems illustrating their commonest applications.

The *shadows* which opaque objects cast on the planes of

projection or on other objects are seldom or never shown on a working drawing, and as the students in Sibley College are taught this subject in a course on Descriptive Geometry, it is omitted here.

CONVENTIONS.

The Source of Light is considered to be at an infinite distance from the object, therefore the Rays of Light will be represented by parallel lines.

The Source of Light is considered to be fixed, and the Point of Sight situated in front of the object and at an infinite distance from it, so that the *Visual Rays* are parallel to one another and per. to the plane of projection.

Shade Lines divide illuminated surfaces from dark surfaces.

Dark surfaces are not necessarily to be defined by those surfaces which are darkened by the shadow cast by another part of the object, but by reason of their location in relation to the rays of light.

It is the general practice to shade-line the different projections of an object as if each projection was in the same plane, e.g., suppose a cube, Fig. 143, situated in space in the third angle, the point of sight in front of it, and the direction of the rays of light coinciding with the diagonal of the cube, as shown by Fig. 144. Then the edges $a''b''$, $b''c''$ will be shade lines, because they are the edges which separate the illuminated faces (the faces upon which fall the rays of light) from the shaded faces, as shown by Fig. 144.

Now the source of light being fixed, let the point of sight remain in the same position, and conceive the object to be revolved through the angle of 90° about a hor. axis so that a

plan at the top of the object is shown above the elevation, and as the projected rays of light falling in the direction of the diagonal of a cube make angles of 45° with the hor., then with the use of the 45° triangle we can easily determine that the lower and right-hand edges of the plan as well as of the elevation should be shade lines.

This practice then will be followed in this work, viz. :
 Shade lines shall be applied to all *projections* of an object,

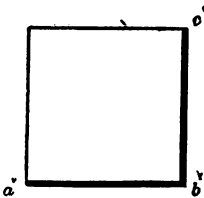
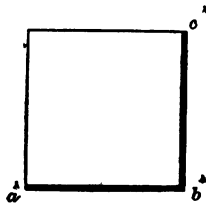

FIG. 143.

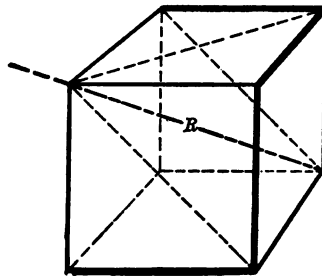

FIG. 144.

considering the rays of light to fall upon each of them, from the same direction.

Shade lines should have a *width* equal to 3 times that of the other outlines. *Broken lines* should never be shade lines.

The outlines of *surfaces of revolution* should not be shade lines. The shade-lined figures which follow will assist in illustrating the above principles; they should be studied until understood.

SHADING.

The *shade* of an object is that part of the surface from which light is excluded by the object.

The *line of shade* is the line separating the shaded from the illuminated part of an object, and is found where the rays of light are tangent to the object.

Brilliant Points.—"When a ray of light falls upon a surface which turns it from its course and gives it another direction, the ray is said to be reflected. The ray as it falls upon the surface is called the incident ray, and after it leaves the surface the reflected ray. The point at which the reflection takes place is called the *point of incidence*.

"It is ascertained by experiment—

"(a) That the plane of the incident and reflected rays is always normal to the surface at the point of incidence;

"(b) That at the point of incidence the incident and reflected rays make equal angles with the tangent plane or normal line to the surface.

"If therefore we suppose a single luminous point and the light emanating from it to fall upon any surface and to be reflected to the eye, the point at which the reflection takes place is called the brilliant point. The brilliant point of a surface is, then, the point at which a ray of light and a line drawn to the eye make equal angles with the tangent plane or normal line—the plane of the two lines being normal to the surface."
—Davies: *Shades and Shadows*.

Considering the rays of light to be parallel and the point of sight at an infinite distance, the brilliant point on the surface of a *sphere* is found as follows: Let A^vC^v and A^hC^h , Fig.

The point of shade can be found as follows:

Draw A^hG , Fig. 145, making an angle of 45° with a hor. Join the points E and F with a straight line EF . Lay off on A^hG a distance equal to EF , and join EG . Parallel to EG

FIG. 146.

FIG. 147.

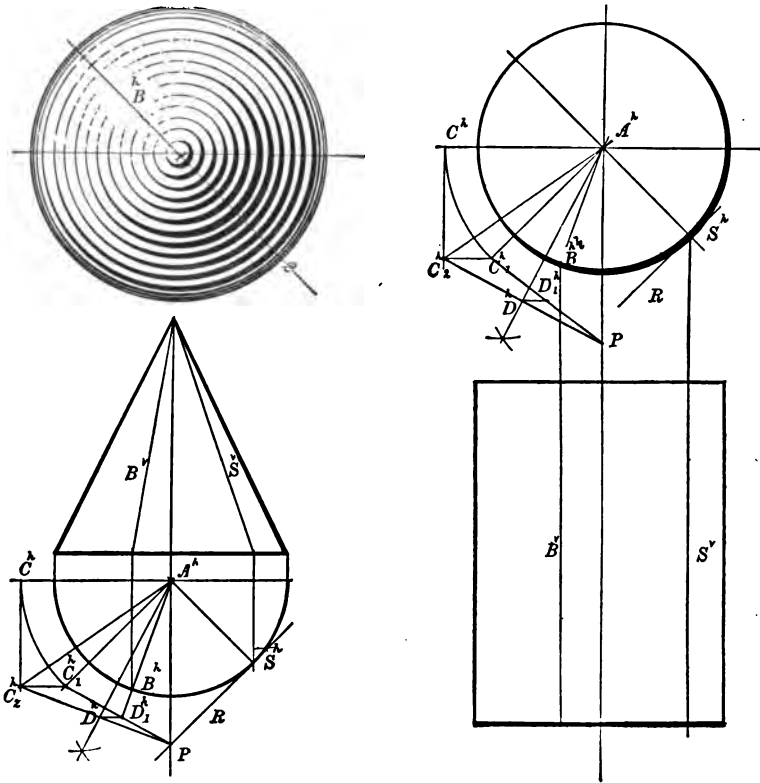

FIG. 148.

draw a tangent to the sphere at the point T . Through T draw TP^h per. to A^hG . From the point P^h drop a per. to P^v . P^v is the point of shade.

PROB. 24.—To shade the elevation of a sphere with graded arcs of circles.

First find the brilliant point and the point of shade, and divide the radius 1, 2 into a suitable number of equal parts, and draw arcs of circles as shown by Fig. 146, grading them by moving the center a short distance on each side of the center of the sphere on the line B^2 and varying the length of the radii to obtain a grade of line that will give a proper shade to the sphere. It is desirable to use a horn center to protect the center of the figure.

Fig. 149 shows the stippling method of shading the sphere.



FIG. 149.

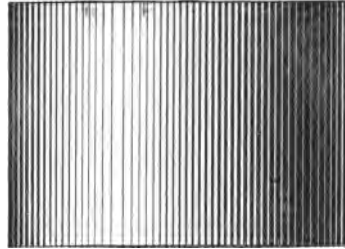

FIG. 150.

PROB. 25.—To shade a right cylinder with graded right lines.

Find the line of light B^o by the same method used to find the brilliant point on the sphere, except that the line of light is projected from the point B^k where the bisection line $A^k D$ cuts the circle of the cylinder.

The line of shade is found where a plane of rays is tangent to the cyl. at S^o and S^k .

Fig. 150 shows how the shading lines are graded from the line of shade to the line of light.

It will be noticed that the lines grow a little narrower to the right of the line of shade on Fig. 150; this shows where

the reflection of the rays of light partly illumine the outline of the cylinder.

PROB. 26, FIG. 148.—To shade a right cone with graded right lines tapering toward the apex of the cone.

Find the elements of light and shade as shown by Fig. 148, and draw the shading-lines as shown by Fig. 151, grading their width toward the light and tapering them toward the apex of the cone.

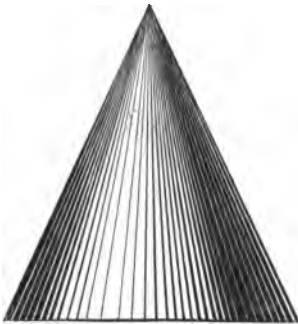

FIG. 151.

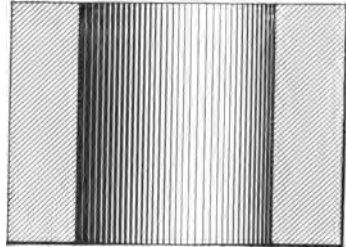

FIG. 152.

The mixed appearance of the lines near the apex of the cone on Fig. 151 can usually be avoided by letting each line dry before drawing another through it, or as some draftsmen do, stop the lines just before they touch.

PROB. 27.—To shade the concave surface of a section of a hollow cylinder.

Find the element of light and grade the shading lines from it to both edges as shown by Fig. 152.

Fig. 153 shows a conventional method of shading a hexagonal nut.

PROB. 28.—To draw a front and end elevation of a rectangular hollow box with a rectangular block on each face, each

block to have a rectangular opening, and all to be properly shade-lined and drawn to the dimensions given on Fig. 154.

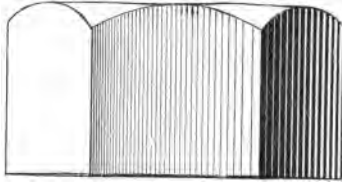

FIG. 153.

Draw the hor. center line first, and then the vertical center line of the end view. About these center lines on the end el-

FIG. 154.

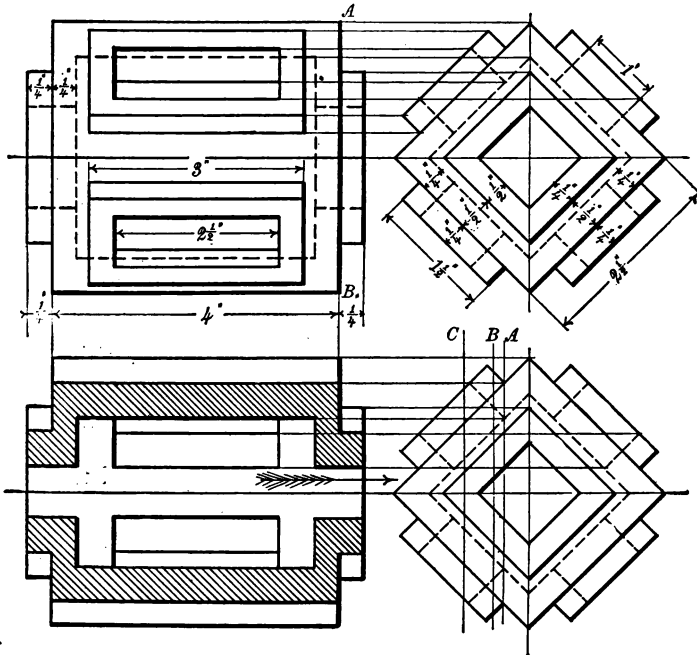

FIG. 155.

evation construct the squares shown and erect the edges of the blocks. Next draw the hidden lines indicating the thickness

of the walls of the box and the openings through the blocks, measuring the sizes carefully to the given dimensions.

Draw the front elevation by projecting lines from the various points on the end elevation, and assuming the position of the line AB measure off the lengths of the hor. lines and erect their vert. boundaries as shown by the figure.

PROB. 29.—Given the end elevation of the last prob., cut by three planes A , B and C , Fig. 155. Draw the projections of these sections when the part to the left of the cutting plane has been removed, and what remains is viewed in the direction of the arrow, remembering that all the visual rays are parallel.

These drawings and all that may follow are to be properly shade-lined in accordance with the principles given above.

ISOMETRICAL DRAWING.

In orthographic projection it is necessary to a correct understanding of an object to have at least two views, a front and end elevation, or an elevation and plan, and sometimes even three views are required.

Isometric drawing on the other hand shows an object completely with only one view. It is a very convenient system for the workshop. Davidson in his *Projection* calls it the "Perspective of the Workshop." It is more useful than perspective for a working drawing, because, as its name implies ("equal measures") it can be made to any scale and measured like an orthographic drawing. It is, however, mainly employed to represent small objects, or large objects drawn to a small scale, whose main lines are at right angles to each other.

The principles of isometrical drawing are founded on a cube resting on its lower front corner, 1, Fig. 156, and its base

elevated so that its diagonal AB is parallel to the horizontal plane. Then if the cube is rotated on the corner 1 until the diagonal AB is at right angles to the vert. plane, i.e., through an angle of 90° , the front elevation will appear as shown at 1, 2, 3, 4, Fig. 156, a regular hexagon.

Now we know that in a regular hexagon, as shown by Fig. 156, the lines $1A$, $A3$, etc., are all equal, and are easily drawn

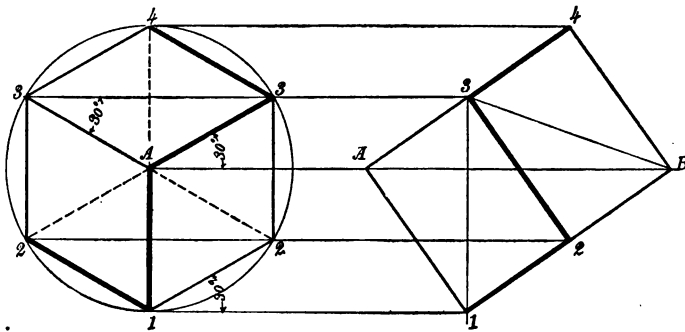

FIG. 156.

with the $30^\circ \times 60^\circ$ triangle. But although these lines and faces appear to be equal, yet, being inclined to the plane of projection, they are shorter than they would actually be on the cube itself. However, since they all bear the same proportion to the original sizes, they can all be measured with the same scale.

We will now describe the method of making an isometrical scale.

Draw the half of a square with sides $= 2\frac{1}{2}''$, Fig. 157. These two sides will make the angle of 45° with the horizontal. Now the sides of the corresponding isometrical square, we have seen, make the angle of 30° with the horizontal, so we will

draw 1 4, 3 4, making angles of 30° with 1, 3. The difference then between the angle 2, 1, 3 and the angle 4, 1, 3 is 15° , and the proportion of the isometrical projection to the actual object is as the length of the line 3, 2 to the line 3, 4. And if the line 3, 2 be divided into any number of equal parts, and lines be drawn through these divisions par. to 2, 4 to cut the line 3, 4 in corresponding divisions, these will divide 3, 4 proportionately to 3, 2.

Now if the divisions on 3, 2 be taken to represent feet and those on 3, 4 to represent 2 feet, then 3, 4 would be an isometrical scale of $\frac{1}{2}$.

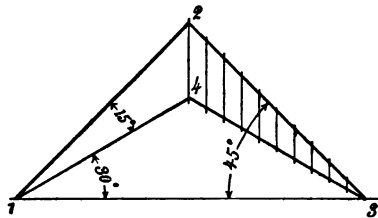

FIG. 157.

Since isometrical drawings may be made to any scale, we may make the isometrical lines of the object = their true size. This is a common practice and precludes the need of a special isometrical scale.

The Direction of the Rays of Light.—The projection of a ray of light in isometrical drawing will make the angle of 30° with the horizontal as shown by the line 3, 2 on the front elevation of the hex., Fig. 156. And the *shade lines* will be applied as in ordinary projection.

PROB. 30.—To make the isometrical drawing of a two-armed cross standing on a square pedestal.

Begin by drawing a center line AB , Fig. 158, and from the point A draw AC and AD , making an angle of 30° with the horizontal. Measure from A on the center line AB a distance $= \frac{5}{16}''$, and draw lines par. to AC , AD ; make AC and AD $2\frac{5}{8}''$ long and erect a perpendicular at D and C , completing the two front sides of the base, etc.

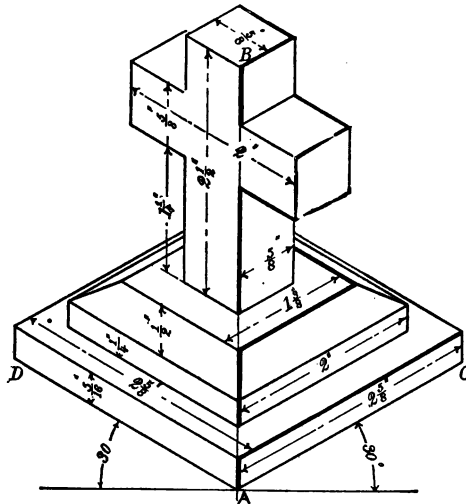

FIG. 158.

PROB. 31.—To make the isometrical drawing of a hollow cube, with square block on each face and a square hole through each block, to dimensions given on Fig. 159.

As before, first draw a center line, and make an isometrical drawing of a $2\frac{1}{2}''$ cube, and upon each face of it build the blocks with the square holes in them, exactly as shown in Fig. 159.

PROB. 32.—To project an isometrical circle.

The circle is enclosed in a square, as shown by Fig. 160.

Draw the circle with a radius = 2" and describe the square 1, 2, 3, 4 about it.

Draw the diagonals 1, 2, 3, 4 and the diameters 5, 6, 7, 8 at right angles to each other.

Now from the points 1 and 2 draw lines 1A, 1B and 2A, 2B, making angles of 30° with the hor. diagonal 1, 2. And

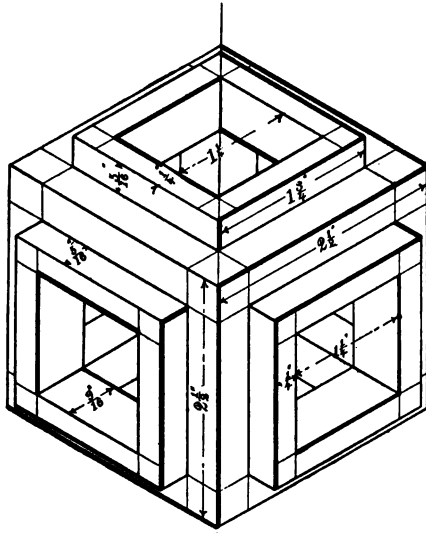

FIG. 159

through the center O draw CD and EF at right angles to the isometrical square.

The points CD , EF , and GH will be points in the curve of the projected isometrical circle, which will be an ellipse.

The ellipse may be drawn sufficiently accurate as follows:

With center B and radius BC describe the arc CF and extend it a little beyond the points C and F , and with center A and same rad. describe a similar arc, then with a rad. which

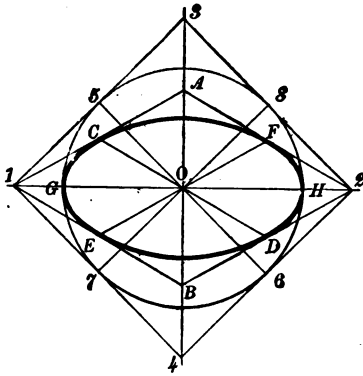

FIG. 160.

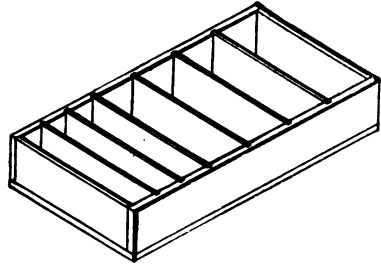

FIG. 161.

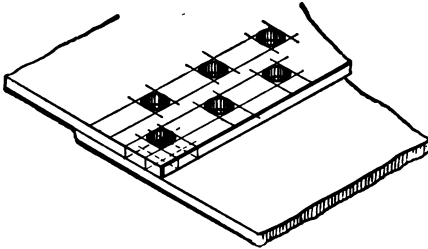

FIG. 162.

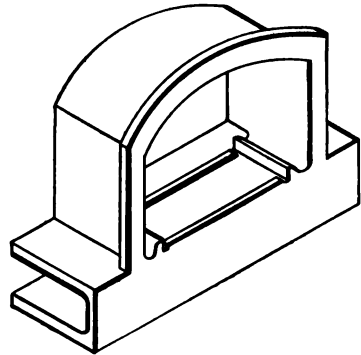

FIG. 163.

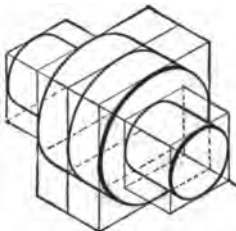

FIG. 164.

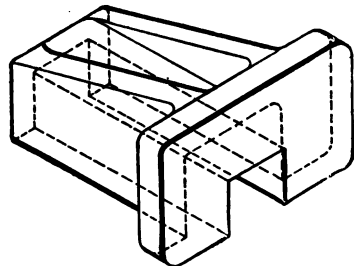

FIG. 165.

may readily be found by trial, draw arcs through the points *G* and *H* and tangent to the two arcs already described.

Figs. 161, 162, 163, 164, 165, and 166 are for practice in the application of the preceding principles, and at least one of these should be drawn, or it would be better still if the stu-

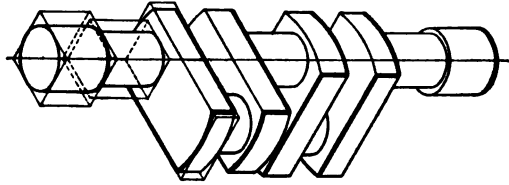

FIG. 166.

dent would attempt to make an isometrical projection of his instrument-box, desk, or any familiar object at hand. These figures may be measured with the $1\frac{1}{2}$ " scale and drawn with the 2" scale.

WORKING DRAWINGS.

Working drawings are sometimes made on brown detail-paper in pencil, traced on tracing-paper or cloth, and then blue printed.

The latter process is accomplished as follows:

The tracing is placed face down on the glass in the printing-frame, and the prepared paper is placed behind it, with the sensitized surface in contact with the back of the tracing.

In printing from a negative the sensitized surface of the prepared paper is placed in contact with the film side of the negative, and the face is exposed to the light.

The blue-print system for working drawings has many drawbacks, e.g., the sectioned parts of the drawing require to

be hatch-lined, using the standard conventions already referred to for the different materials. This takes a great deal of time. The print has usually to be mounted on cardboard, although this is not always done, and unless it is varnished the frequent handling with dirty, oily fingers soon makes it unfit for use.

Changes can be made on the prints with soda-water, it is true, but they seldom look well, and when many changes or additions require to be made it is best to make them on the tracing and take a new print. And the sunlight is not always favorable to quick printing. So taking everything into consideration the system of making working drawings directly on cards and varnishing them is probably the best. It is the system used by the Schenectady Locomotive Works and many other large engineering establishments. In size the cards are made $9'' \times 12''$, $12'' \times 18''$, $18'' \times 24''$; they are made of thick pasteboard mounted with Irish linen record-paper. The drawings are pencilled and inked on these cards in the usual way, and the sections are tinted with the conventional colors, which are much quicker applied than hatch-lines. The face of the drawing is protected with two coats of white shellac varnish, while the back of the card is usually given a coat of orange shellac.

The white varnish can easily be removed with a little alcohol, and changes made on the drawing, and when revarnished it is again ready for the shop.

We will now try to describe what a working drawing is and what it is for. In the hands of an experienced workman a working drawing is intended to convey to him all the necessary information as to shape, size, material, and finish to

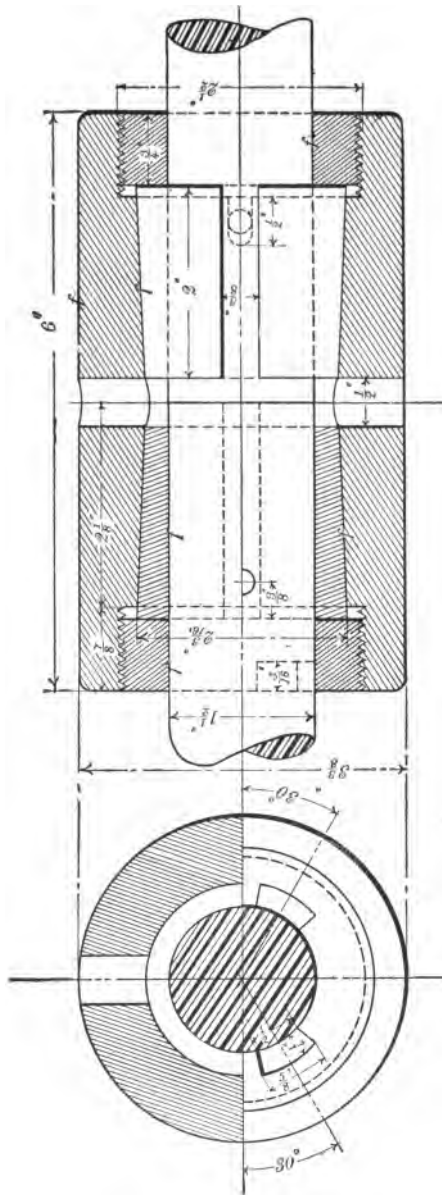

FIG. 167.

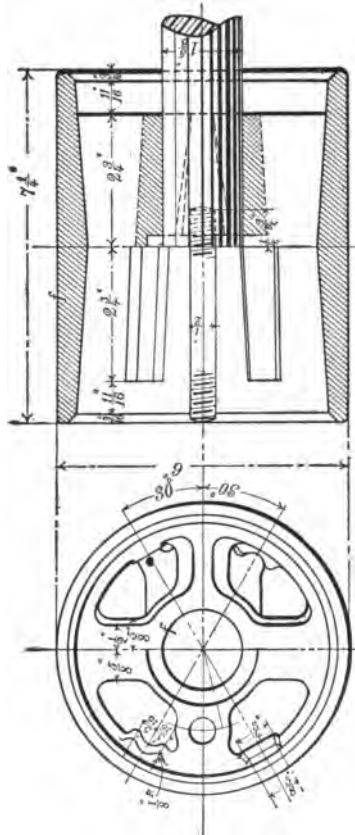
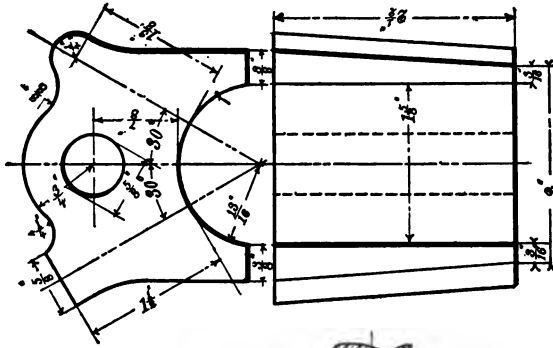

FIG. 168.

enable him to properly construct it without any additional instructions. This means that it must have a sufficient number of elevations, sections, and plans to thoroughly explain and describe the object in every particular. And these views should be completely and conveniently dimensioned. The dimensions on the drawing must of course give the sizes to which the object is to be made, without reference to the scale to which it may be drawn. The title of a working drawing should be as brief as possible, and not very large—a neat, plain, free-hand printed letter is best for this purpose.

Finished parts are usually indicated by the letter “f,” and if it is all to be finished, then below the title it is customary to write or print “finished all over.”

The number of the drawing may be placed at the upper left-hand corner, and the *initials* of the draftsman immediately below it.

A second-year course, entitled *Mechanical Drawing and Elementary Machine Design*, is in preparation, and will shortly be published.

Figs. 167 and 168 show working drawings of two shaft-couplings, fully figured, sectioned, and shade-lined.

INDEX.

A

	PAGE
Angle, To bisect an.....	19
Angle, To construct an.....	15
Anti-friction curve, "Schiele's".....	50
Arched window-opening, To draw an.....	53
Arkansas oil-stones.....	5

B

Baluster, To draw a.....	53
Board, Drawing.....	1
Bow instruments.....	2
Brass, Sheet of.....	6
Breaks, Conventional.....	61
Brilliant points.....	106

C

Celluloid, Sheet of thin.....	5
Center lines.....	60
Cinquefoil ornament, To draw the.....	53
Circle, Arc of a, To find the center of an.....	32
Circle, Arc of a, To draw a line tangent to an.....	33
Circle, To draw a right line equal to half the circumference of a.....	31
Circle, To draw a tangent between two.....	33
Circle, To draw tangents to two.....	34
Circle, To draw an arc of a, tangent to two straight lines.....	34
Circle, To inscribe a, within a triangle.....	35
Circle, To draw an arc of a, tangent to two circles.....	36
Circle, To draw an arc of a, tangent to a straight line and a circle.....	37
Circle, To construct the involute of a.....	45
Circle, To find the length of an arc of a, approximately.....	47

	PAGE
Cisoid, To draw the.....	49
Compass.....	2
Conventions.....	56
Conventions, Shading.....	104
Conventional breaks.....	61
Conventional lines.....	60
Conventional screw-threads.....	62
Cross-sections.....	62
Curves, Irregular.....	3
Cycloid, To describe the.....	46

D

Dark surfaces.....	104
Development of the surfaces of a hexagonal prism.....	90
Development of the surface of a right cylinder.....	92
Development of the surface of a cone.....	93
Development of the surface of a cylindrical dome.....	96
Development of a locomotive gusset sheet.....	97
Dihedral angles.....	75
Direction, The, of the rays of light.....	105
Dividers, Hair-spring.....	2
Drawing-board.....	1
Drawing-pen.....	2
Drawing to scale.....	12, 54

E

Ellipse, To describe an.....	38
Ellipse, Given an, to find the axes and foci.....	43
Epicycloid, To describe the.....	48
Epicycloid, To describe an interior.....	50
Equilateral triangle, To construct an.....	24
Examples of working drawings.....	120

F

Figuring and lettering.....	66
Finished parts of working drawings.....	122

G

Geometrical drawing.....	16
Glass-paper pencil sharpener.....	4
Gothic letters.....	69

H

	PAGE
Heptagon, To construct a.....	28
Hyperbola, To draw an.....	42
Hypocycloid, To describe the.....	48

I

Ink eraser.....	4
Inks.....	4
Instruments.....	2
Intersection, The, of a cylinder with a cone.....	93
Intersection, The, of two cylinders.....	96
Intersection, The, of a plane with an irregular surface of revolution.....	102
Involute, of a circle, To construct the.....	45
Isometrical cube.....	113
Isometrical drawing.....	112
Isometrical drawing, Direction of the rays of light in.....	114
Isometrical drawing of a two-armed cross.....	115
Isometrical drawing of a hollow cube.....	116
Isometrical drawing, Examples of.....	117
Isometrical scale, The.....	114

L

Leads for compass.....	13
Lettering and figuring.....	64
Line of shade.....	106
Line, To draw a, parallel to another.....	19
Line, To divide a.....	21
Line of motion.....	60
Line of section.....	60

M

Mechanical drawing and elementary machine design.....	122
Model of the co-ordinate planes.....	81
Moulding, The "Scotia".....	51
Moulding, The "Cyma Recta".....	51
Moulding, The "Cavetto" or "Hollow".....	51
Moulding, The "Echinus," "Quatrefoil," or "Ovolo".....	52
Moulding, The "Apophygee".....	52
Moulding, The "Cyma Reversa".....	52
Moulding, The "Torus".....	52

N	
	PAGE
Needles.....	6
Notation.....	80
O	
Octagon, To construct an.....	28
Orthographic projection.....	74
Oval, To construct an.....	43
P	
Paper.....	2
Parabola, To construct a.....	41
Pencil.....	2
Pencil eraser.....	4
Pencil, To sharpen the.....	8
Pen, Drawing.....	9
Pen, To sharpen the drawing.....	10
Pentagon, To construct a.....	28
Perpendicular, To erect a.....	17
Planes of projection, The.....	75
Polygon, To construct a.....	26
Projection, The, of straight lines.....	82
Projection, The, of plane surfaces.....	84
Projection, The, of solids.....	90
Projection, The, of the cone.....	93
Projection of the helix as applied to screw-threads.....	99
Proportional, To find a <i>mean</i> , to two given lines.....	31
Proportional, To find a <i>third</i> , to two given lines.....	31
Proportional, To find a <i>fourth</i> , to three given lines.....	32
Protractor.....	6
Q	
Quatrefoil, To draw the.....	53
R	
Rays of light.....	104
Rays, Visual.....	104
Rhomboid, To construct the.....	21
Right angle, To trisect a.....	24
Roman letters.....	67

S

	PAGE
Scale guard.....	6
Scale, Drawing to.....	12, 54
Scale, To construct a.....	55
Schiele's curve, To draw.....	50
Screw-threads, Conventional.....	62
Screw-threads, Regular.....	100
Section lines.....	56
Section lines, Standard.....	58
Shade lines and shading.....	103
Shade, To, the elevation of a sphere.....	108
Shade, To, a right cylinder.....	109
Shade, To, a right cone.....	110
Shade, To, a concave cylindrical surface.....	110
Sharpen pencil, To.....	8
Sharpen pen, To.....	10
Sheet brass.....	6
Sheet celluloid.....	6
"Sibley College" set of irregular curves.....	3
"Sibley College" set of instruments.....	2
Source of light.....	104
Spiral, To describe the.....	44
Sponge rubber.....	5
Square, To construct a.....	25
Stippling.....	109

T

Tacks.....	5
T-square.....	2
Third dihedral angle.....	75
Tinting brush.....	5
Tinting saucer.....	5
Title, The, of a working drawing.....	122
Tracing-cloth.....	6
Trefoil, To describe the.....	53
Triangles.....	3
Triangle, To construct a.....	25
Triangular scale.....	3
Type specimens.....	70

U

Use of instruments.....	7
Use of pencil.....	8

	PAGE
Use of drawing-pen	9
Use of triangles	11
Use of T-square	11
Use of drawing-board	11
Use of scale	12
Use of compasses	13
Use of dividers or spacers	13
Use of spring bows	14
Use of irregular curves	14
Use of protractor	14

V

Visual rays	104
Volute, To describe the "Ionic"	45

W

Water-colors	5
Water glass	5
Writing-pen	6
Working drawings	118
Working drawings, Method of making	119
Working drawing, What is a	119
Working drawings, Examples of	119



SHORT-TITLE CATALOGUE

OF THE

PUBLICATIONS

OF

JOHN WILEY & SONS,

NEW YORK.

LONDON: CHAPMAN & HALL, LIMITED.

ARRANGED UNDER SUBJECTS.

Descriptive circulars sent on application.

Books marked with an asterisk are sold at net prices only.

All books are bound in cloth unless otherwise stated.

AGRICULTURE.

CATTLE FEEDING—DAIRY PRACTICE—DISEASES OF ANIMALS— GARDENING, ETC.

Armsby's Manual of Cattle Feeding.....	12mo,	\$1 75
Downing's Fruit and Fruit Trees.....	8vo,	5 00
Grotenfelt's The Principles of Modern Dairy Practice. (Woll.)		
	12mo,	2 00
Kemp's Landscape Gardening.....	12mo,	2 50
Lloyd's Science of Agriculture.....	8vo,	4 00
Loudon's Gardening for Ladies. (Downing.).....	12mo,	1 50
Steel's Treatise on the Diseases of the Dog.....	8vo,	3 50
“ Treatise on the Diseases of the Ox.....	8vo,	6 00
Stockbridge's Rocks and Soils....	8vo,	2 50
Woll's Handbook for Farmers and Dairymen.....	12mo,	1 50

ARCHITECTURE.

BUILDING—CARPENTRY—STAIRS—VENTILATION, ETC.

Berg's Buildings and Structures of American Railroads....	4to,	7 50
Birkmire's American Theatres—Planning and Construction.	8vo,	3 00
“ Architectural Iron and Steel.....	8vo,	3 50
“ Compound Riveted Girders.....	8vo,	2 00
“ Skeleton Construction in Buildings.....	8vo,	3 00
“ Planning and Construction of High Office Buildings.		
	8vo,	3 50

Carpenter's Heating and Ventilating of Buildings.....	8vo.	\$3 00
Downing, Cottages	8vo,	2 50
" Hints to Architects.....	8vo,	2 00
Freitag's Architectural Engineering.....	8vo,	2 50
Gerhard's Sanitary House Inspection.....	16mo,	1 00
" Theatre Fires and Panics.....	12mo,	1 50
Hatfield's American House Carpenter.....	8vo,	5 00
Holly's Carpenter and Joiner.. ..	18mo,	75
Kidder's Architect and Builder's Pocket-book.....	Morocco flap,	4 00
Merrill's Stones for Building and Decoration.....	8vo,	5 00
Monckton's Stair Building—Wood, Iron, and Stone.....	.4to,	4 00
Wait's Engineering and Architectural Jurisprudence.....	8vo,	6 00
	Sheep,	6 50
Worcester's Small Hospitals—Establishment and Maintenance, including Atkinson's Suggestions for Hospital Archi- tecture... ..	12mo,	1 25
World's Columbian Exposition of 1893.....	.4to,	2 50

ARMY, NAVY, Etc.

MILITARY ENGINEERING—ORDNANCE—PORT CHARGES—LAW, ETC.

Bourne's Screw Propellers4to,	5 00
Bruff's Ordnance and Gunnery.....	8vo,	6 00
Bucknill's Submarine Mines and Torpedoes.....	8vo,	4 00
Chase's Screw Propellers	8vo,	3 00
Cooke's Naval Ordnance	8vo,	12 50
Cronkhite's Gunnery for Non-com. Officers.....	18mo, morocco,	2 00
Davis's Treatise on Military Law.....	8vo,	7 00
	Sheep,	7 50
" Elements of Law	8vo,	2 50
De Brack's Cavalry Outpost Duties. (Carr.).....	18mo, morocco,	2 00
Dietz's Soldier's First Aid.....	12mo, morocco,	1 25
* Dredge's Modern French Artillery.....	.4to, half morocco,	15 00
" Record of the Transportation Exhibits Building, World's Columbian Exposition of 1893.....	.4to, half morocco,	10 00
Durand's Resistance and Propulsion of Ships.....	8vo,	5 00
Dyer's Light Artillery.....	12mo,	3 00
Hoff's Naval Tactics.....	8vo,	1 50
Hunter's Port Charges.....	8vo, half morocco,	13 00

Hayford's Text-book of Geodetic Astronomy.....	8vo.	
Michie and Harlow's Practical Astronomy.....	8vo,	\$3 00
White's Theoretical and Descriptive Astronomy.....	12mo,	2 00

BOTANY.

GARDENING FOR LADIES, ETC.

Baldwin's Orchids of New England.....	8vo,	1 50
Loudon's Gardening for Ladies. (Downing.).....	12mo,	1 50
Thomé's Structural Botany.....	18mo,	2 25
Weltermaier's General Botany. (Schneider.).....	8vo,	2 00

BRIDGES, ROOFS, Etc.

CANTILEVER—DRAW—HIGHWAY—SUSPENSION.

(See also ENGINEERING, p. 6.)

Boller's Highway Bridges.....	8vo,	2 00
* " The Thames River Bridge.....	4to, paper,	5 00
Burr's Stresses in Bridges....	8vo,	3 50
Crehore's Mechanics of the Girder.....	8vo,	5 00
Dredge's Thames Bridges.....	7 parts, per part,	1 25
Du Bois's Stresses in Framed Structures.....	4to,	10 00
Foster's Wooden Trestle Bridges.....	4to,	5 00
Greene's Arches in Wood, etc.....	8vo,	2 50
" Bridge Trusses.....	8vo,	2 50
" Roof Trusses.....	8vo,	1 25
Howe's Treatise on Arches.....	8vo,	4 00
Johnson's Modern Framed Structures.....	4to,	10 00
Merriman & Jacoby's Text-book of Roofs and Bridges.		
Part I., Stresses.....	8vo,	2 50
Merriman & Jacoby's Text-book of Roofs and Bridges.		
Part II., Graphic Statics.....	8vo.	2 50
Merriman & Jacoby's Text-book of Roofs and Bridges.		
Part III., Bridge Design.....	8vo,	2 50
Merriman & Jacoby's Text-book of Roofs and Bridges.		
Part IV., Continuous, Draw, Cantilever, Suspension, and Arched Bridges.....	8vo,	2 50
* Morison's The Memphis Bridge.....	Oblong 4to,	10 00

Waddell's Iron Highway Bridges.....	8vo,	\$4 00
" De Pontibus (a Pocket-book for Bridge Engineers).		
Wood's Construction of Bridges and Roofs.....	8vo,	2 00
Wright's Designing of Draw Spans.....	8vo,	2 50

CHEMISTRY.

QUALITATIVE—QUANTITATIVE—ORGANIC—INORGANIC, ETC.

Adriance's Laboratory Calculations.....	12mo,	1 25
Allen's Tables for Iron Analysis.....	8vo,	3 00
Austen's Notes for Chemical Students.....	12mo,	1 50
Bolton's Student's Guide in Quantitative Analysis.....	8vo,	1 50
Classen's Analysis by Electrolysis. (Herrick and Boltwood.)	8vo,	3 00
Crafts's Qualitative Analysis. (Schaeffer.).....	12mo,	1 50
Drechsel's Chemical Reactions. (Merrill.).....	12mo,	1 25
Fresenius's Quantitative Chemical Analysis. (Allen.).....	8vo,	6 00
" Qualitative " " (Johnson.)....	8vo,	3 00
" " " " (Wells) Trans. 16th.		
German Edition.....	8vo,	5 00
Fuerte's Water and Public Health.....	12mo,	1 50
Gill's Gas and Fuel Analysis.....	12mo,	1 25
Hammarsten's Physiological Chemistry. (Mandel.).....	8vo,	4 00
Helm's Principles of Mathematical Chemistry. (Morgan).	12mo,	1 50
Kolbe's Inorganic Chemistry.....	12mo,	1 50
Ladd's Quantitative Chemical Analysis.....	12mo,	1 00
Landauer's Spectrum Analysis. (Tingle.).....	8vo,	3 00
Mandel's Bio-chemical Laboratory.....	12mo,	1 50
Mason's Water-supply.....	8vo,	5 00
" Analysis of Potable Water. (<i>In the press.</i>)		
Miller's Chemical Physics.....	8vo,	2 00
Mixter's Elementary Text-book of Chemistry.....	12mo,	1 50
Morgan's The Theory of Solutions and its Results.....	12mo,	1 00
Nichols's Water-supply (Chemical and Sanitary).....	8vo,	2 50
O'Brine's Laboratory Guide to Chemical Analysis.....	8vo,	2 00
Perkins's Qualitative Analysis.....	12mo,	1 00
Pinner's Organic Chemistry. (Austen.).....	12mo,	1 50
Poole's Calorific Power of Fuels.....	8vo,	3 00
Ricketts and Russell's Notes on Inorganic Chemistry (Non-metallic).....	Oblong 8vo, morocco,	75

Ruddiman's Incompatibilities in Prescriptions.....	8vo,	\$2 00
Schimpf's Volumetric Analysis.....	12mo,	2 50
Spencer's Sugar Manufacturer's Handbook. 12mo, morocco flaps,		2 00
" Handbook for Chemists of Beet Sugar House,	12mo, morocco,	3 00
Stockbridge's Rocks and Soils.....	8vo,	2 50
Troilius's Chemistry of Iron.....	8vo,	2 00
Wells's Inorganic Qualitative Analysis.....	12mo,	1 50
" Laboratory Guide in Qualitative Chemical Analysis, 8vo,		1 50
Wiechmann's Chemical Lecture Notes.....	12mo,	3 00
" Sugar Analysis.....	8vo,	2 50
Wulling's Inorganic Phar. and Med. Chemistry.....	12mo,	2 00

DRAWING.

ELEMENTARY—GEOMETRICAL—TOPOGRAPHICAL.

Hill's Shades and Shadows and Perspective.....	8vo,	2 00
MacCord's Descriptive Geometry.....	8vo,	3 00
" Kinematics.....	8vo,	5 00
" Mechanical Drawing.....	8vo,	4 00
Mahan's Industrial Drawing. (Thompson.).....	2 vols., 8vo,	3 50
Reed's Topographical Drawing. (II. A.).....	4to,	5 00
Reid's A Course in Mechanical Drawing.....	8vo.	2 00
" Mechanical Drawing and Elementary Machine Design.	8vo.	
Smith's Topographical Drawing. (Macmillan.).....	8vo,	2 50
Warren's Descriptive Geometry.....	2 vols., 8vo,	3 50
" Drafting Instruments.....	12mo,	1 25
" Free-hand Drawing.....	12mo,	1 00
" Higher Linear Perspective.....	8vo,	3 50
" Linear Perspective.....	12mo,	1 00
" Machine Construction.....	2 vols., 8vo,	7 50
" Plane Problems.....	12mo,	1 25
" Primary Geometry.....	12mo,	75
" Problems and Theorems.....	8vo,	2 50
" Projection Drawing.....	12mo,	1 50
" Shades and Shadows.....	8vo,	3 00
" Stereotomy—Stone Cutting.....	8vo,	2 50
Whelpley's Letter Engraving.....	12mo,	2 00

ELECTRICITY AND MAGNETISM.

ILLUMINATION—BATTERIES—PHYSICS.

Anthony and Brackett's Text-book of Physics (Magie).	8vo,	\$4 00
Barker's Deep-sea Soundings.	8vo,	2 00
Benjamin's Voltaic Cell.	8vo,	3 00
" History of Electricity.	8vo	3 00
Cosmic Law of Thermal Repulsion.	18mo,	75
Crehore and Squier's Experiments with a New Polarizing Photo- Chronograph.	8vo,	3 00
* Dredge's Electric Illuminations.	2 vols., 4to, half morocco,	25 00
" " " Vol. II.	4to,	7 50
Gilbert's De magnete. (Mottelay).	8vo,	2 50
Holman's Precision of Measurements.	8vo,	2 00
Michie's Wave Motion Relating to Sound and Light.	8vo,	4 00
Morgan's The Theory of Solutions and its Results.	12mo,	1 00
Niaudet's Electric Batteries. (Fishback.)	12mo,	2 50
Reagan's Steam and Electrical Locomotives.	12mo,	2 00
Thurston's Stationary Steam Engines for Electric Lighting Pur- poses.	12mo,	1 50
Tillman's Heat.	8vo,	1 50

ENGINEERING.

CIVIL—MECHANICAL—SANITARY, ETC.

(See also BRIDGES, p. 4; HYDRAULICS, p. 8; MATERIALS OF EN-
GINEERING, p. 9; MECHANICS AND MACHINERY, p. 11; STEAM ENGINES
AND BOILERS, p. 14.)

Baker's Masonry Construction.	8vo,	5 00
" Surveying Instruments.	12mo,	3 00
Black's U. S. Public Works.	4to,	5 00
Brook's Street Railway Location.	12mo, morocco,	1 50
Butts's Engineer's Field-book.	12mo, morocco,	2 50
Byrne's Highway Construction.	8vo,	7 50
" Inspection of Materials and Workmanship. 12mo, mor.		
Carpenter's Experimental Engineering	8vo,	6 00
Church's Mechanics of Engineering—Solids and Fluids.	8vo,	6 00
" Notes and Examples in Mechanics.	8vo,	2 00
Crandall's Earthwork Tables	8vo,	1 50
" The Transition Curve.	12mo, morocco,	1 50

* Dredge's Penn. Railroad Construction, etc.	Folio, half mor.,	\$20 00
* Drinker's Tunnelling	4to, half morocco,	25 00
Eissler's Explosives—Nitroglycerine and Dynamite	8vo,	4 00
Fowler's Cofferdam Process for Piers	8vo,	
Gerhard's Sanitary House Inspection	16mo,	1 00
Godwin's Railroad Engineer's Field-book	12mo, pocket-bk. form,	2 50
Gore's Elements of Geodesy	8vo,	2 50
Howard's Transition Curve Field-book	12mo, morocco flap,	1 50
Howe's Retaining Walls (New Edition.)	12mo,	1 25
Hudson's Excavation Tables. Vol. II.	8vo,	1 00
Hutton's Mechanical Engineering of Power Plants	8vo,	5 00
Johnson's Materials of Construction	8vo,	6 00
" Stadia Reduction Diagram. Sheet, 22½ × 28½ inches,		50
" Theory and Practice of Surveying	8vo,	4 00
Kent's Mechanical Engineer's Pocket-book	12mo, morocco,	5 00
Kiersted's Sewage Disposal	12mo,	1 25
Kirkwood's Lead Pipe for Service Pipe	8vo,	1 50
Mahan's Civil Engineering. (Wood.)	8vo,	5 00
Merriman and Brook's Handbook for Surveyors	12mo, mor.,	2 00
Merriman's Geodetic Surveying	8vo,	2 00
" Retaining Walls and Masonry Dams	8vo,	2 00
Mosely's Mechanical Engineering. (Mahan.)	8vo,	5 00
Nagle's Manual for Railroad Engineers	12mo, morocco,	3 00
Patton's Civil Engineering	8vo,	7 50
" Foundations	8vo,	5 00
Rockwell's Roads and Pavements in France	12mo,	1 25
Ruffner's Non-tidal Rivers	8vo,	1 25
Searles's Field Engineering	12mo, morocco flaps,	3 00
" Railroad Spiral	12mo, morocco flaps,	1 50
Siebert and Biggin's Modern Stone-Cutting and Masonry	8vo,	1 50
Smith's Cable Tramways	4to,	2 50
" Wire Manufacture and Uses	4to,	3 00
Spalding's Roads and Pavements	12mo,	2 00
" Hydraulic Cement	12mo,	2 00
Thurston's Materials of Construction	8vo,	5 00
* Trautwine's Civil Engineer's Pocket-book	12mo, mor. flaps,	5 00
* " Cross-section	Sheet,	25
* " Excavations and Embankments	8vo,	2 00

* Trautwine's Laying Out Curves.....	12mo, morocco,	\$2 50
Waddell's De Pontibus (A Pocket-book for Bridge Engineers).	12mo, morocco,	3 00
Walt's Engineering and Architectural Jurisprudence.....	8vo,	6 00
" Law of Field Operation in Engineering, etc.....	8vo,	6 50
Warren's Stereotomy—Stone Cutting.....		2 50
Webb's Engineering Instruments.....	12mo, morocco,	1 00
Wegmann's Construction of Masonry Dams.....	4to,	5 00
Wellington's Location of Railways.....	8vo,	5 00
Wheeler's Civil Engineering.....	8vo,	4 00
Wolf's Windmill as a Prime Mover.....	8vo,	3 00

HYDRAULICS.

WATER-WHEELS—WINDMILLS—SERVICE PIPE—DRAINAGE, ETC.

(See also ENGINEERING, p. 6.)

Bazin's Experiments upon the Contraction of the Liquid Vein (Trautwine).....	8vo,	2 00
Bovey's Treatise on Hydraulics.....	8vo,	4 00
Coffin's Graphical Solution of Hydraulic Problems.....	12mo,	2 50
Ferrel's Treatise on the Winds, Cyclones, and Tornadoes..	8vo,	4 00
Fuerte's Water and Public Health.....	12mo,	1 50
Ganguillet & Kutter's Flow of Water. (Hering & Trautwine.)	8vo,	4 00
Hazen's Filtration of Public Water Supply.....	8vo,	2 00
Herschel's 115 Experiments	8vo,	2 00
Kiersted's Sewage Disposal.....	12mo,	1 25
Kirkwood's Lead Pipe for Service Pipe	8vo,	1 50
Mason's Water Supply.....	8vo,	5 00
Merriman's Treatise on Hydraulics.....	8vo,	4 00
Nichols's Water Supply (Chemical and Sanitary).....	8vo,	2 50
Ruffner's Improvement for Non-tidal Rivers.....	8vo,	1 25
Wegmann's Water Supply of the City of New York	4to,	10 00
Weisbach's Hydraulics. (Du Bois.).....	8vo,	5 00
Wilson's Irrigation Engineering....	8vo,	4 00
" Hydraulic and Placer Mining.....	12mo,	2 00
Wolf's Windmill as a Prime Mover.....	8vo,	3 00
Wood's Theory of Turbines.....	8vo,	2 50

MANUFACTURES.

ANILINE—BOILERS—EXPLOSIVES—IRON—SUGAR—WATCHES— WOOLLENS, ETC.

Allen's Tables for Iron Analysis.....	8vo,	3 00
Beaumont's Woollen and Worsted Manufacture.....	12mo,	1 50
Bollaud's Encyclopædia of Founding Terms.....	12mo,	3 00

Bolland's The Iron Founder.....	12mo,	2 50
" " " " Supplement.....	12mo,	2 50
Booth's Clock and Watch Maker's Manual.....	12mo,	2 00
Bouvier's Handbook on Oil Painting.....	12mo,	2 00
Eissler's Explosives, Nitroglycerine and Dynamite.....	8vo,	4 00
Ford's Boiler Making for Boiler Makers.....	18mo,	1 00
Metcalf's Cost of Manufactures.....	8vo,	5 00
Metcalf's Steel—A Manual for Steel Users.....	12mo,	\$2 00
Reimann's Aniline Colors. (Crookes.).....	8vo,	2 50
* Reisig's Guide to Piece Dyeing.....	8vo,	25 00
Spencer's Sugar Manufacturer's Handbook....	12mo, mor. flap,	2 00
" Handbook for Chemists of Beet Houses.	12mo, mor. flap,	3 00
Svedelius's Handbook for Charcoal Burners.....	12mo,	1 50
The Lathe and Its Uses.....	8vo,	6 00
Thurston's Manual of Steam Boilers.....	8vo,	5 00
Walke's Lectures on Explosives.....	8vo,	4 00
West's American Foundry Practice.....	12mo,	2 50
" Moulder's Text-book	12mo,	2 50
Wiechmann's Sugar Analysis.....	8vo,	2 50
Woodbury's Fire Protection of Mills.....	8vo,	2 50

MATERIALS OF ENGINEERING.

STRENGTH—ELASTICITY—RESISTANCE, ETC.

(See also ENGINEERING, p. 6.)

Baker's Masonry Construction.....	8vo,	5 00
Beardslee and Kent's Strength of Wrought Iron.....	8vo,	1 50
Bovey's Strength of Materials.....	8vo,	7 50
Burr's Elasticity and Resistance of Materials.....	8vo,	5 00
Byrne's Highway Construction.....	8vo,	5 00
Carpenter's Testing Machines and Methods of Testing Materials.		
Church's Mechanics of Engineering—Solids and Fluids... ..	8vo,	6 00
Du Bois's Stresses in Framed Structures.....	4to,	10 00
Hatfield's Transverse Strains.....	8vo,	5 00
Johnson's Materials of Construction.....	8vo,	6 00
Lanza's Applied Mechanics.....	8vo,	7 50
Merrill's Stones for Building and Decoration.....	8vo,	5 00
Merriman's Mechanics of Materials.....	8vo,	4 00
" Strength of Materials.....	12mo,	1 00
Patton's Treatise on Foundations.....	8vo,	5 00
Rockwell's Roads and Pavements in France.....	12mo,	1 25
Spalding's Roads and Pavements.....	12mo,	2 00
Thurston's Materials of Construction.....	8vo,	5 00

Thurston's Materials of Engineering.....	3 vols., 8vo,	\$3 00
Vol. I., Non-metallic	8vo,	2 00
Vol. II., Iron and Steel.....	8vo,	3 50
Vol. III., Alloys, Brasses, and Bronzes.....	8vo,	2 50
Weyrauch's Strength of Iron and Steel. (Du Bois.).....	8vo,	1 50
Wood's Resistance of Materials.....	8vo,	2 00

MATHEMATICS.

CALCULUS—GEOMETRY—TRIGONOMETRY, ETC.

Baker's Elliptic Functions.....	8vo,	1 50
Ballard's Pyramid Problem.....	8vo,	1 50
Barnard's Pyramid Problem.....	8vo,	1 50
Bass's Differential Calculus.....	12mo,	4 00
Brigg's Plane Analytical Geometry.....	12mo,	1 00
Chapman's Theory of Equations.....	12mo,	1 50
Chessin's Elements of the Theory of Functions.		
Compton's Logarithmic Computations.....	12mo,	1 50
Craig's Linear Differential Equations.....	8vo,	5 00
Davis's Introduction to the Logic of Algebra.....	8vo,	1 50
Halsted's Elements of Geometry.....	8vo,	1 75
" Synthetic Geometry.....	8vo,	1 50
Johnson's Curve Tracing.....	12mo,	1 00
" Differential Equations—Ordinary and Partial....	8vo,	3 50
" Integral Calculus.....	12mo,	1 50
" " " Unabridged.		
" Least Squares.....	12mo,	1 50
Ludlow's Logarithmic and Other Tables. (Bass.).....	8vo,	2 00
" Trigonometry with Tables. (Bass.).....	8vo,	3 00
Mahan's Descriptive Geometry (Stone Cutting).....	8vo,	1 50
Merriman and Woodward's Higher Mathematics.....	8vo,	5 00
Merriman's Method of Least Squares.....	8vo,	2 00
Parker's Quadrature of the Circle.....	8vo,	2 50
Rice and Johnson's Differential and Integral Calculus,		
2 vols. in 1, 12mo,		2 50
" Differential Calculus.....	8vo,	3 00
" Abridgment of Differential Calculus....	8vo,	1 50
Searles's Elements of Geometry.....	8vo,	1 50
Totten's Metrology.....	8vo,	2 50
Warren's Descriptive Geometry.....	2 vols., 8vo,	3 50
" Drafting Instruments.....	12mo,	1 25
" Free-hand Drawing.....	12mo,	1 00
" Higher Linear Perspective.....	8vo,	3 50
" Linear Perspective.....	12mo,	1 00
" Primary Geometry.....	12mo,	75

Warren's Plane Problems.....	12mo,	\$1 25
“ Problems and Theorems.....	8vo,	2 50
“ Projection Drawing.....	12mo,	1 50
Wood's Co-ordinate Geometry.....	8vo,	2 00
“ Trigonometry.....	12mo,	1 00
Woolf's Descriptive Geometry.....	Royal 8vo,	8 00

MECHANICS—MACHINERY.

TEXT-BOOKS AND PRACTICAL WORKS.

(See also ENGINEERING, p. 6.)

Baldwin's Steam Heating for Buildings.....	12mo,	2 50
Benjamin's Wrinkles and Recipes.....	12mo,	2 00
Carpenter's Testing Machines and Methods of Testing Materials.....	8vo.	
Chordal's Letters to Mechanics.....	12mo,	2 00
Church's Mechanics of Engineering.....	8vo,	6 00
“ Notes and Examples in Mechanics.....	8vo,	2 00
Crehore's Mechanics of the Girder.....	8vo,	5 00
Cromwell's Belts and Pulleys.....	12mo,	1 50
“ Toothed Gearing.....	12mo,	1 50
Compton's First Lessons in Metal Working.....	12mo,	1 50
Dana's Elementary Mechanics.....	12mo,	1 50
Dingey's Machinery Pattern Making.....	12mo,	2 00
Dredge's Trans. Exhibits Building, World Exposition, 4to, half morocco,		10 00
Du Bois's Mechanics. Vol. I., Kinematics.....	8vo,	3 50
“ “ Vol. II., Statics.....	8vo,	4 00
“ “ Vol. III., Kinetics.....	8vo,	3 50
Fitzgerald's Boston Machinist.....	18mo,	1 00
Flather's Dynamometers.....	12mo,	2 00
“ Rope Driving.....	12mo,	2 00
Hall's Car Lubrication.....	12mo,	1 00
Holly's Saw Filing.....	18mo,	75
Johnson's Theoretical Mechanics. An Elementary Treatise. (In the press.)		
Jones Machine Design. Part I., Kinematics.....	8vo,	1 50
“ “ “ Part II., Strength and Proportion of Machine Parts.		
Lanza's Applied Mechanics.....	8vo,	7 50
MacCord's Kinematics.....	8vo,	5 00
Merriman's Mechanics of Materials.....	8vo,	4 00
Metcalfe's Cost of Manufactures.....	8vo,	5 00
Michie's Analytical Mechanics.....	8vo,	4 00
Mosely's Mechanical Engineering. (Mahan.).....	8vo,	5 00

Dana's Descriptive Mineralogy. (E. S.)8vo, half morocco,	\$12 50
“ Mineralogy and Petrography (J.D.)12mo,	2 00
“ Minerals and How to Study Them. (E. S.)12mo,	1 50
“ Text-book of Mineralogy. (E. S.)8vo,	8 50
*Drinker's Tunnelling, Explosives, Compounds, and Rock Drills. 4to, half morocco,	25 00
Egleston's Catalogue of Minerals and Synonyms8vo,	2 50
Eisler's Explosives—Nitroglycerine and Dynamite.8vo,	4 00
Goodyear's Coal Mines of the Western Coast12mo,	2 50
Hussak's Rock-forming Minerals. (Smith.)8vo,	2 00
Ihlseng's Manual of Mining8vo,	4 00
Kunhardt's Ore Dressing in Europe8vo,	1 50
O'Driscoll's Treatment of Gold Ores8vo,	2 00
Rosenbusch's Microscopical Physiography of Minerals and Rocks. (Iddings)8vo,	5 00
Sawyer's Accidents in Mines8vo,	7 00
Stockbridge's Rocks and Soils8vo,	2 50
Walke's Lectures on Explosives8vo,	4 00
Williams's Lithology8vo,	3 00
Wilson's Mine Ventilation16mo,	1 25
“ Hydraulic and Placer Mining12mo.	

STEAM AND ELECTRICAL ENGINES, BOILERS, Etc.

STATIONARY—MARINE—LOCOMOTIVE—GAS ENGINES, ETC.

(See also ENGINEERING, p. 6.)

Baldwin's Steam Heating for Buildings12mo,	2 50
Clerk's Gas Engine12mo,	4 00
Ford's Boiler Making for Boiler Makers18mo,	1 00
Hemenway's Indicator Practice12mo,	2 00
Hoadley's Warm-blast Furnace8vo,	1 50
Kness's Practice and Theory of the Injector8vo,	1 50
MacCord's Slide Valve8vo,	2 00
* Maw's Marine EnginesFolio, half morocco,	18 00
Meyer's Modern Locomotive Construction4to,	10 00
Peabody and Miller's Steam Boilers8vo,	4 00
Peabody's Tables of Saturated Steam8vo,	1 00
“ Thermodynamics of the Steam Engine8vo,	5 00
“ Valve Gears for the Steam Engine8vo,	2 50
Pray's Twenty Years with the IndicatorRoyal 8vo,	2 50
Pupin and Osterberg's Thermodynamics12mo,	1 25
Réagan's Steam and Electrical Locomotives12mo,	2 00
Röntgen's Thermodynamics. (Du Bois.)8vo,	5 00
Sinclair's Locomotive Running12mo,	2 00
Thurston's Boiler Explosion12mo,	1 50

Thurston's Engine and Boiler Trials	8vo,	\$5 00
“ Manual of the Steam Engine. Part I., Structure and Theory	8vo,	7 50
“ Manual of the Steam Engine. Part II., Design, Construction, and Operation	8vo,	7 50
	2 parts,	12 00
“ Philosophy of the Steam Engine	12mo,	75
“ Reflection on the Motive Power of Heat. (Carnot.)	12mo,	1 50
“ Stationary Steam Engines	12mo,	1 50
“ Steam-boiler Construction and Operation	8vo,	5 00
Spungler's Valve Gears	8vo,	2 50
Trowbridge's Stationary Steam Engines	4to, boards,	2 50
Weisbach's Steam Engine. (Du Bois.)	8vo,	5 00
Whitham's Constructive Steam Engineering	8vo,	10 00
“ Steam-engine Design	8vo,	5 00
Wilson's Steam Boilers. (Flather.)	12mo,	2 50
Wood's Thermodynamics, Heat Motors, etc.	8vo,	4 00

TABLES, WEIGHTS, AND MEASURES.

FOR ACTUARIES, CHEMISTS, ENGINEERS, MECHANICS—METRIC TABLES, ETC.

Adriance's Laboratory Calculations	12mo,	1 25
Allen's Tables for Iron Analysis	8vo,	3 00
Bixby's Graphical Computing Tables	Sheet,	25
Compton's Logarithms	12mo,	1 50
Crandall's Railway and Earthwork Tables	8vo,	1 50
Egleston's Weights and Measures	18mo,	75
Fisher's Table of Cubic Yards	Cardboard,	25
Hudson's Excavation Tables. Vol. II.	8vo,	1 00
Johnson's Stadia and Earthwork Tables	8vo,	1 25
Ludlow's Logarithmic and Other Tables. (Bass.)	12mo,	2 00
Thurston's Conversion Tables	8vo,	1 00
Totten's Metrology	8vo,	2 50

VENTILATION.

STEAM HEATING—HOUSE INSPECTION—MINE VENTILATION.

Baldwin's Steam Heating	12mo,	2 50
Beard's Ventilation of Mines	12mo,	2 50
Carpenter's Heating and Ventilating of Buildings	8vo,	3 00
Gerhard's Sanitary House Inspection	Square 16mo,	1 00
Mott's The Air We Breathe, and Ventilation	16mo,	1 00
Reid's Ventilation of American Dwellings	12mo,	1 50
Wilson's Mine Ventilation	16mo,	1 25

MISCELLANEOUS PUBLICATIONS.

Alcott's Gems, Sentiment, Language.....	Gilt edges,	\$5 00
Bailey's The New Tale of a Tub.....	8vo,	75
Ballard's Solution of the Pyramid Problem.....	8vo,	1 50
Barnard's The Metrological System of the Great Pyramid.....	8vo,	1 50
Davis's Elements of Law.....	8vo,	2 00
Emmon's Geological Guide-book of the Rocky Mountains.....	8vo,	1 50
Ferrel's Treatise on the Winds.....	8vo,	4 00
Huines's Addresses Delivered before the Am. Ry. Assn.....	12mo,	2 50
Mott's The Fallacy of the Present Theory of Sound.....	Sq. 16mo,	1 00
Perkins's Cornell University.....	Oblong 4to,	1 50
Ricketts's History of Rensselaer Polytechnic Institute.....	8vo,	3 00
Rotherham's The New Testament Critically Emphasized.....	12mo,	1 50
" The Emphasized New Test. A new translation.....	Large 8vo,	2 00
Totten's An Important Question in Metrology.....	8vo,	2 50
Whitehouse's Lake Mæris.....	Paper,	25
* Wiley's Yosemite, Alaska, and Yellowstone.....	4to,	3 00

HEBREW AND CHALDEE TEXT-BOOKS.

FOR SCHOOLS AND THEOLOGICAL SEMINARIES.

Gesenius's Hebrew and Chaldee Lexicon to Old Testament. (Tregelles.).....	Small 4to, half morocco,	5 00
Green's Elementary Hebrew Grammar.....	12mo,	1 25
" Grammar of the Hebrew Language (New Edition).....	8vo,	3 00
" Hebrew Chrestomathy.....	8vo,	2 00
Letteris's Hebrew Bible (Massoretic Notes in English).....	8vo, arabesque,	2 25
Luzzato's Grammar of the Biblical Chaldaic Language and the Talmud Babli Idioms.....	12mo,	1 50

MEDICAL.

Bull's Maternal Management in Health and Disease.....	12mo,	1 00
Hammarsten's Physiological Chemistry. (Mandel.).....	8vo,	4 00
Mott's Composition, Digestibility, and Nutritive Value of Food. Large mounted chart.....		1 25
Ruddiman's Incompatibilities in Prescriptions.....	8vo,	2 00
Steel's Treatise on the Diseases of the Ox.....	8vo,	6 00
" Treatise on the Diseases of the Dog.....	8vo,	3 50
Woodhull's Military Hygiene.....	12mo,	1 50
Worcester's Small Hospitals—Establishment and Maintenance, including Atkinson's Suggestions for Hospital Archi- tecture.....	12mo,	1 25







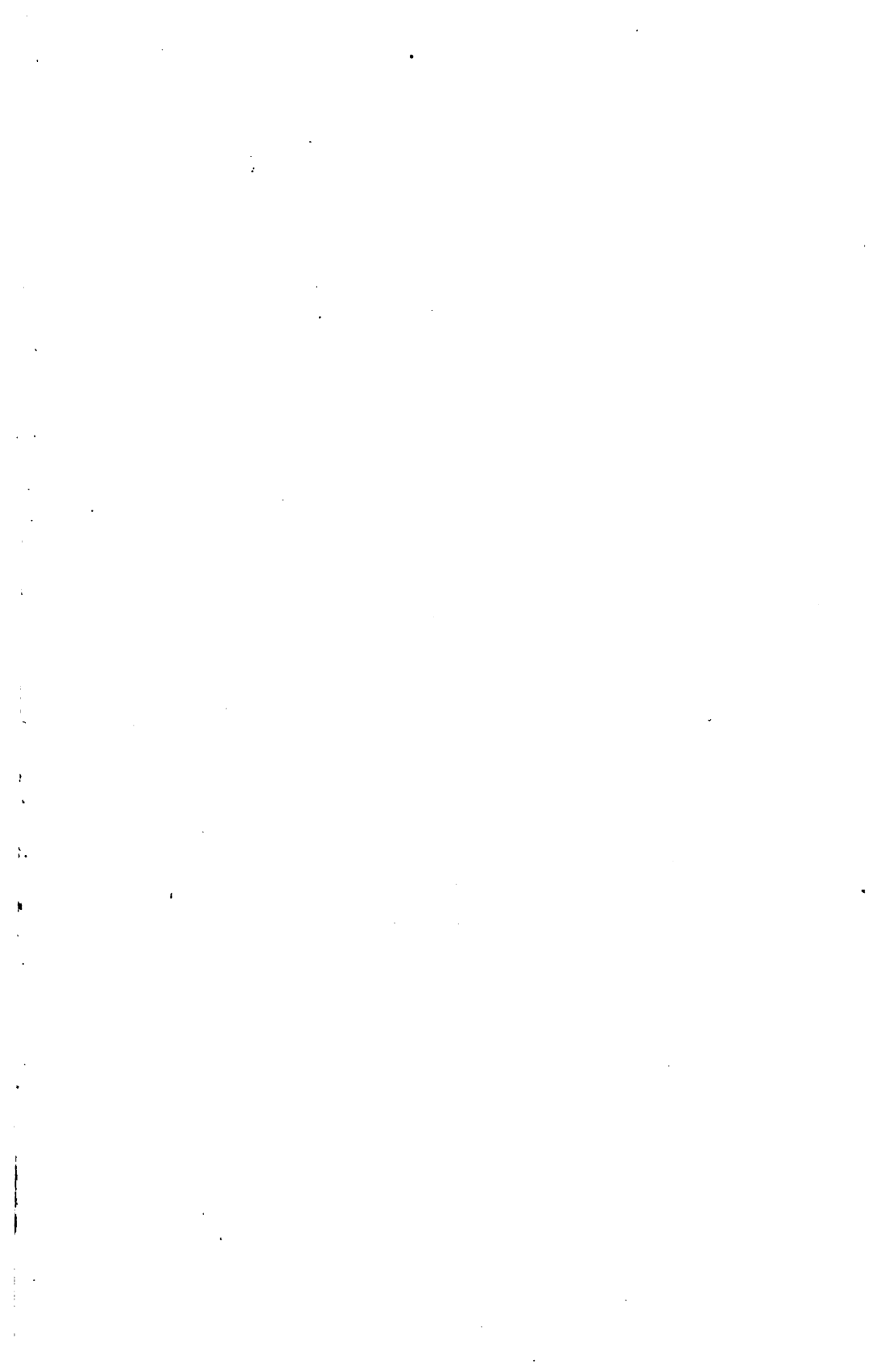

UNIVERSITY OF CALIFORNIA LIBRARY
BERKELEY

Return to desk from which borrowed.
This book is DUE on the last date stamped below.

17 May 51

3 May 51

15 Mar 55

WAR 17 1955 LU

NOV 25 1979

Returned by

APR 22 1980

Sania Cruz Library

REC. CIR. APR 22 1980

T 353- 288

R4

75022



